

BIG FLO

Accu-Flo
Meter Service Ltd.

www.accuflo.com
1-800-921-ACCU

Submersible Pumps

INSTALLATION, OPERATION,
SERVICE & REPAIR PARTS



INSTALLATION, OPERATION, SERVICE & REPAIR PARTS MANUAL

– FOR –

RED JACKET “Big-Flo[®]” – High Capacity Gasoline Pumps Submersible Type

**Model Numbers - P200R1-2MB*, P200R4-2MB*, P300R4-2HB*, P300R17-3HB*,
P500R4-2K*, P500R6-2K*, P500R17-3K***

* A Suffix number is added to the end of these model numbers designating the pump length in inches. A suffix “-SY” after the model number designates syphon. A suffix “-AE” after the model number designates air eliminator.

NOTICE

This pumping system requires the following elements:

1. Discharge Manifold Assembly – Installed below grade (NEC/Class I, Group D, Division I area)
2. Motor-Pump Unit Assembly – Installed below grade (NEC/Class I, Group D, Division I area)
3. Control Box/Magnetic Starter or Magnetic Contactor

All of the above are U.L. Listed when used as a complete system.

An “all inclusive” name plate will be found attached to the extractor nipple seal and can be inspected by removing the manhole cover directly over the pump. An additional name plate will be found on the control box.

NOTICE

It is important to give the model number and serial number of this pump when corresponding with the factory for any reason.

ATTENTION INSTALLER

READ THIS IMPORTANT SAFETY INFORMATION BEFORE BEGINNING WORK

The following defined terms are used throughout this manual to bring attention to the presence of hazards of various risk levels, or to important information concerning the life of the product.

DANGER

indicates presence of a hazard which *will* cause *severe* personal injury, death or substantial property damage if ignored.

CAUTION

indicates presence of a hazard which *will* or *can* cause *minor* personal injury or property damage if ignored.

WARNING

indicates presence of a hazard which *can* cause *severe* personal injury, death or substantial property damage if ignored.

NOTICE

indicates special instructions on installations, operation, or maintenance which are important but not related to personal injury hazards.

DANGER

Portions of this product are to be installed and operated in the highly combustible environment of a gasoline storage tank. It is essential that you carefully read and follow the warnings and instructions in this manual to protect yourself and others from hazards which will result in serious personal injury, death or severe property damage.

WARNING Failure to follow all instructions in proper order can cause personal injury or death. Read all instructions before installing. All installation work must comply with local code requirements. If no other codes apply, the latest issue of the National Electrical Code should be followed.

Installation of Red Jacket petroleum equipment should be performed only by personnel who are trained and qualified to do so.

1. Units should be installed with manholes, or with discharge manifold casting above grade, to allow for ease in servicing.

WARNING Red Jacket line leak detection systems do not function if the submersible pump runs continuously. Running a pump continuously will cause line leak detection systems to not function which results in a hazard that can cause severe personal injury, death or property damage.

2. Never wire a submersible pump to run continuously at less than minimum flow rate. The units are designed to operate continuously at or above minimum flow rate, or with an intermittent duty cycle, not to exceed 20 on/off cycles per hour. Should it be necessary to operate a unit continuously or when the demand is at a rate less than required per the information below, a bypass pipe should be installed in the piping to allow for continual product recirculation back into the storage tank. Regulation of the bypass flow back to the tank can be accomplished by correct sizing of the bypass line or use of a gate valve. The recommended minimum bypass per unit is:

60 Hz, 208-240 VOLT, TWO STAGE UNITS

P200R1-2MB=15 GPM

P200R4-2MB=15 GPM

P300R4-2HB=20 GPM

P500R4-2K=25 GPM

P500R6-2K=25 GPM

50 Hz, 380-415 VOLT, THREE STAGE UNITS

P300R17-3HB=20 GPM

P500R17-3K=25 GPM

3. Red Jacket submersibles are not designed to handle abrasives or foreign particles in the product being pumped.
4. Product temperature must never exceed 105°F (41°C) as the submersible motors are equipped with thermal overload protection. Product temperature higher than 105°F (41°C) may result in tripping of the thermal overload protector.
5. Pumping water will overload the motor and damage the motor bearings.
6. These units are designed for use in Class I, Group D atmospheres.
7. Install pumping system in accordance to applicable codes.

WARNING Proper motor protection must be used on the 5 H.P., 575 VOLT three phase pump models, or motor warranty is void. To maintain warranty, the magnetic starters used must be supplied by Red Jacket, or have equivalent protection features defined as follows: 3 leg protection, properly sized quick trip heaters, and ambient temperature compensated overloads.

FOLLOW DIRECTIONS CAREFULLY

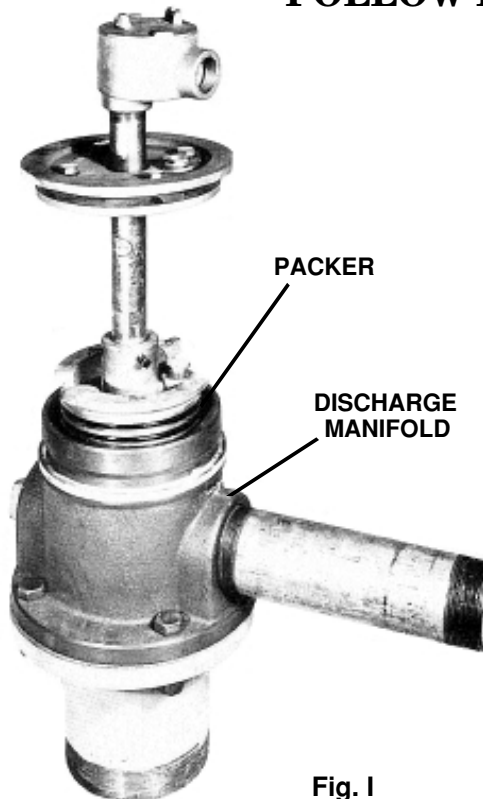

Fig. 1

A. Installing Pumping Unit

NOTICE Check these points before installing:

1. Power supply against equipment voltage rating. For 3 phase units, request power company identify and tag service wires for L1-L2-L3 phase sequence.
2. Be certain that pump with syphon valve is installed in proper tank.
3. Check equipment received against table on Fig. VII for tank diameter and bury depth.

CAUTION Use waterproof non-setting thread sealant approved for gasoline service on all threads.

4. Install 6" Riser and Flange into tank opening.
5. Apply gasket compound to gasket and place on riser flange. Place Discharge Manifold on gasket to line up outlets as desired. Insert and tighten four cap screws.
6. Install piping from Discharge Manifold outlets to Dispensers and/or loading rack. One or both outlets can be used.

NOTICE Installation of a Ball Valve is recommended on the discharge side of the pump or discharge of the Big Flo leak detector housing if used. This will aid in troubleshooting and line testing.

Line check valves are not required as the pump is equipped with a built-in Check Valve. However, whenever two pumps are manifolded together to the



Fig. II

same discharge piping, check valves with expansion relief are required and should be installed in the piping in discharge of each pump, as close to pump housing as possible.

5. Install 1-1/4" Conduit.
 - a. On some installations, the short piece of 1-1/4" conduit furnished with the pump is of proper length.
 - b. If not of proper length, a new piece of 1-1/4" conduit must be cut and threaded. Measure the length of the 8" diameter extractor nipple pipe. Cut and thread the 1-1/4" conduit 1-1/2" (40 mm) longer than the 8" diameter extractor nipple pipe. Thread the new piece of 1-1/4" conduit into the packer and tighten. Thread sealant should be used. Tighten the two set screws in the packer securely against the 1-1/4" conduit.
6. Install Pumping Unit.
 - a. Apply a small amount of lubricating oil to each "O" ring on Packer. Also lubricate the "O" ring sealing surfaces inside the Discharge Manifold.
 - b. Install the Pumping Unit through the Discharge Manifold. Care should be taken to lower the unit as near vertical as possible, and slowly to prevent damage to "O" rings or expansion relief valves.
 - c. Refer to Figures I, II and III. The two "stops" on the locking ramps at the top of the packer must be lined up with the corresponding "tabs" at the top of the discharge manifold (see Fig. I).

Lower the pumping unit through the manifold using rocking force, if needed, until the packer is down as far as possible (see Fig. II).

Using a pipe wrench on the 1-1/4" conduit, turn counter-clockwise (to the left when viewed from the top), to lock the pumping unit in.

As soon as the locking ramps engage under the "tabs" the unit is locked in place and does not require any further tightening (see Fig. III).

NOTICE

The locking action does not cause the "O" rings to make a seal.

NOTICE
LOCK PUMP
AS SHOWN
IN FIG. III →

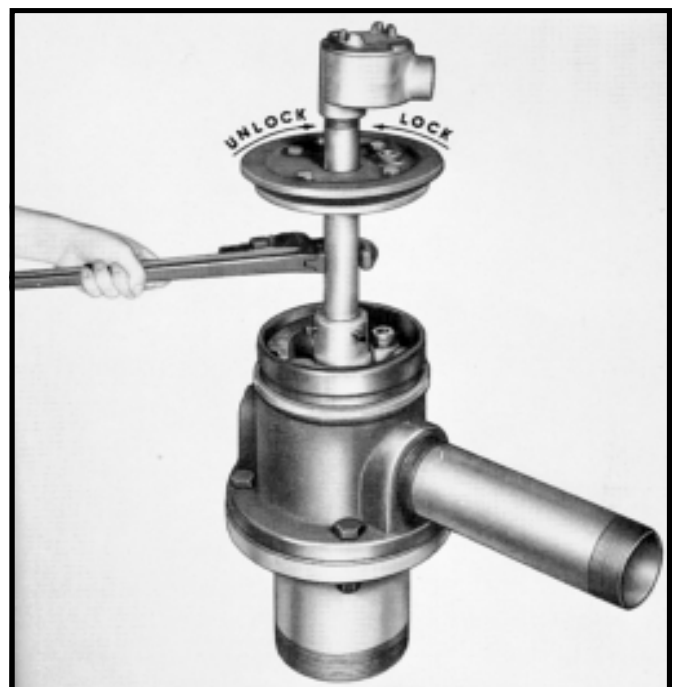
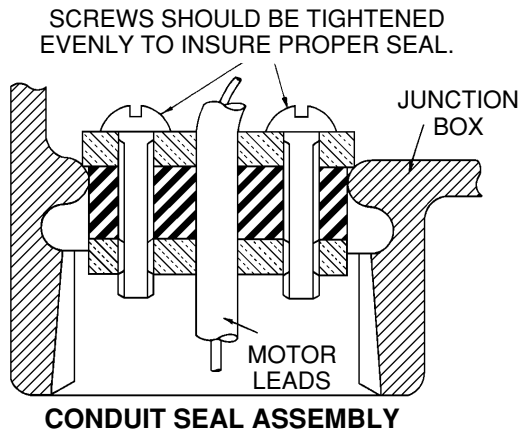

Fig. III



CONDUIT SEAL ASSEMBLY
Fig. IV

7. Pumps with Built-In Siphon Valve (see Fig. VI).
 - a. On some installations, the short piece of 1/4" vacuum pipe furnished with the syphon pumps is of proper length.
 - b. If not of the proper length, replace with length of 1/4" pipe, 1" (25 mm) longer than the 8" diameter Extractor Nipple. Cover top of 1/4" pipe to keep clean during installation.
8. Install 8" Diameter Extractor Nipple (see table on page 15, Fig. VII for length).
 - a. Position the end with set screws onto the rubber ring gasket on the Discharge Manifold. Tighten the four set screws evenly to pull the 8" pipe down on the ring gasket. Torque to 20 ft.-lbs. (27 n-m).
9. Install Extractor Nipple Seal.
 - a. Install the extractor seal in position as shown on Fig. VI. After this seal is in place, tighten the four bolts to force the sealing rings against the extractor nipple and the conduit. Torque to 90 ft.-lbs. (122 n-m).
10. Install Elbow, Fittings & Syphon Check Valve. (This step applies to syphon units only.)
 - a. Install elbow and syphon check valve on top of the 1/4" vacuum pipe and then run 3/8" copper tubing from the elbow to the bushing at the high point of the syphon manifold shown on Page 16. Tighten nut which compresses the gasket around the 1/4" vacuum pipe. Torque to 90 ft.-lbs. (122 n-m).
11. Install Junction Box.
 - a. Next, install the Junction Box on top of the conduit. If necessary to readjust position, do so by tightening box if possible (not loosening box). When tightening Junction Box, hold 1-1/4" conduit secure with pipe wrench to prevent unlocking packer in discharge manifold. Replace rubber seal into bottom of Junction Box as shown on Fig. IV. After positioning as shown, tighten screws firmly to form a tight seal.

B. Wiring Instructions – 208-240 volt Single Phase Pumps

The motor control box must be located away from the fueling area in a nonhazardous location (see Fig. Va).

1. Connect the single phase 208-240 V power supply from the distribution panel to terminals L₁ and L₂ in the motor control box. Each control box should be wired through a separate fused disconnect switch or circuit breaker (including neutral, when used), furnished by customer.
2. Using properly color coded wires, connect wires from terminals red, black and orange on motor control box terminal strip to the corresponding color coded wires in the junction box of the proper submerged pump.
3. The "on-off" control station must be of explosion-proof construction. Where loading racks and dispensers are served by the same submerged pump, the 2-wire switches must be connected in parallel so the submerged pump can be controlled from any dispenser or any loading rack.
4. On the 2 HP pumps, connect wires from terminal BL2 and terminal 3 in motor control box to dispenser control switches (if dispensers are used) and "on-off" switch at loading rack as shown in Fig. Va.
5. If an external pilot light is desired to indicate when the submerged pump is operating, wire as shown in Fig. Va, Vb or Vc. Should this light continue to burn when all switches at dispensers and loading racks are off, this indicates that one of the dispenser switches is out of adjustment. On installations with no external pilot light, the submerged pump should be checked to make sure it is not operating when all switches are turned off.
6. The magnetic contactor coil is shipped ready to accept 208-240 volts. No changes are required unless a 110-120 volt coil is desired. If so, rewire the coil per the wiring diagram label on the side of the contactor. **Disconnect** and remove the wire that connects terminal W and L2 of the contactor. **Connect a new wire** from terminal W to terminal NEU of the terminal strip. The neutral of the power supply must be brought in to NEU. If an electronic dispenser is used, connect the "hot" from the dispenser to terminal 3. (See Fig. Vc).

NOTICE

3-Wire control requires the use of an auxiliary contact in the magnetic contactor. The auxiliary contact is not standard equipment in the magnetic contactor supplied by Red Jacket and must be ordered as a option. Use Furnas auxiliary field kit 49D22125001 or equivalent.

C. Wiring Instructions – 208-240 volt or 400 volt Three Phase Pumps

CAUTION

On some installations "phase converters" are used to obtain a three phase power supply from a single phase power source. The use of phase converters may cause an imbalance between the three phases and cause damage to the motor. For this reason, warranty coverage will not be extended on units installed with phase converters.

1. Installations where magnetic contactor is located away from the fueling area in a nonhazardous location, see Fig. Vd.
 - a. Connect the three phase 208-240 volt or 400 volt power supply from the master panel to terminals L1, L2 and L3 in the magnetic contactor.
 - b. *Using properly color coded wires*, connect a black wire from terminal T1 in the magnetic contactor to the black motor lead in the junction box of the proper submerged pump. Connect an orange wire from contactor terminal T2 to the orange motor lead and a red wire from terminal T3 to the red motor lead. (See Fig. Ve and Vf.)
 - c. The 279-328-5 magnetic contactor is shipped with the coil wired to accept 208-240 V, 60 HZ. It may be rewired to accept 110-120 V. The 279-329-5 magnetic contactor is shipped with the coil wired to accept 380-440V, 50 HZ. It may be rewired to accept 190-220 V.

To connect high voltage to the coil, connect a wire from L2 to terminal V of the contractor coil. To connect low voltage to the coil, rewire the coil per the wiring diagram lable on the side of the contactor. Next, connect a wire from terminal V of the coil to Neutral.

- d. Connect a blue wire from contactor terminal L3 to one side of the "on-off" controls. The "on-off" controls, if furnished by the customer, must be of explosion proof construction.
- e. Installations using dispensers must be connected for 2-wire control as shown on Fig. Ve. Connect a black wire from the other side of the "on-off" switch to terminal W of the magnetic contactor coil. For electronic dispensers with switched "hot", connect "hot" to terminal W (See fig. Vg.)
- f. Installations using loading racks only, may be connected for two- or three-wire control. (See Fig. Ve and Vf.) For three-wire control, connect a red wire from one side of the auxiliary contact to the "on/off" switch. Connect a black wire from the other side of the "on/off" switch to terminal W of the magnetic contactor coil.

NOTICE 3-wire control requires the use of an auxiliary contact in the magnetic contactor. This auxiliary contact is not standard equipment in the magnetic contactor supplied by Red Jacket, and must be ordered as an option. Use Furnas auxiliary field kit, P/N 49D22125001 or equivalent.

WARNING Installations with the magnetic contactor in a hazardous location require explosion proof enclosures. The wiring is the same as for general purpose enclosures.

2. Motor Rotation.

Where it is not convenient to predetermine the power supply phase rotation, proper rotation can be determined by pump performance. Pump head pressure and capacity will be considerably less than rated when rotating backwards.

Connect the pump motor leads to terminal T1, T2 and T3 of the magnetic contactor observing color code shown in Fig. Vd. With gasoline in the tank and the system purged of air, start the motor and make a pressure gauge reading of the system pressure with the discharge valves closed; or, open one valve and calculate pumping rate.

Next, reverse power leads at L1 and L2. Repeat either pressure or flow tests, as described above. If results are higher than the first test, the rotation of the second test is correct. If the second test gives lower performance than the first, reconnect the power leads to L1 and L2 (as under test 1) for correct rotation.

Where the power supply has been properly marked L1, L2 and L3 in accordance with accepted phase rotation standards, it is possible to predetermine the proper rotation of these units. The motor power leads are color coded black, orange and red, and if connected through the magnetic contactor to L1, L2 and L3 respectively, the motor pump unit will rotate in the correct direction (see Fig. Vd). It is recommended, however, that the performance tests always be made whether or not the power supply has been properly "phased out".

D. Wiring Instructions – 575 volt Three Phase Pump

CAUTION On some installations "phase converters" are used to obtain a three phase power supply from a single phase power source. The use of phase converters may cause an imbalance between the three phases and cause damage to the motor. For this reason, warranty coverage will not be extended on units installed with phase converters.

1. Installations where magnetic starter is located away from the loading rack in a nonhazardous location. (See Fig. Vh.)
 - a. Connect the three phase 575 volt power supply from the master panel to terminals L1, L2 and L3 in the magnetic starter.
 - b. *Using properly color coded wires*, connect a black wire from terminal T1 in the magnetic starter to the black motor lead, in the junction box of the proper submerged pump. Connect an orange wire from starter terminal T2 to the orange motor lead and a red wire from terminal T3 to the red motor lead. (See Fig. Vh through Vk.)
 - c. The 279-327-5 magnetic starter is shipped with the coil wired to accept 208-240 V, 60 HZ. It may be rewired to accept 110-120 V.

To connect 208-240 volts to the coil, connect a wire from L2 to terminal V of the contactor coil.

To connect 110-120 volts to the coil, rewire the coil per the wiring diagram label on the side of the contactor. Next, connect a wire from terminal V of the coil to neutral.

The 279-230-5 magnetic starter is shipped with the coil wired to accept 575 V, 60 HZ. It cannot be rewired.

- d. There are two remaining blue wires in the submerged pump junction box. Connect either blue wire to terminal L3 in the Magnetic Starter. Connect the other blue wire to one side of the "on-off" controls or switched "hot" from electronic dispenser (see Fig. Vk.) The "on-off" controls, if furnished by customer, must be of explosion proof construction.
- e. Installations using dispensers must be connected for 2-wire control as shown on Fig. Vh and Vi. Connect a black wire from the other side of the "on-off" switch to terminal 3 in the magnetic starter.
- f. Installations using loading racks only, may be connected for two or three wire control. (See Fig. Vh through Vi.) For three wire control, connect a black wire from terminal 3 in the magnetic starter to the "on-off" switch. Connect a red wire from terminal 2 in the magnetic starter to the "on-off" switch. See Figure Vi for mechanical dispensers and Figure Vk for electronic dispensers.

NOTICE

3-wire control requires the use of an auxiliary contact in the magnetic starter. This auxiliary contact is not standard equipment in the starters supplied by Red Jacket, and must be ordered as an option. Use Furnas auxiliary field kit 49D22125001 or equivalent.

WARNING

Installations with the magnetic starter in a hazardous location require explosion proof starters. The wiring is the same as for general purpose enclosures.

2. Motor Rotation.

Where it is not convenient to predetermine the power supply phase rotation, proper rotation can be determined by pump performance. Pump head pressure and capacity will be considerably less than rated when rotating backwards.

Connect the pump motor leads to terminal T1, T2 and T3 of the magnetic starter observing color code shown in Fig. Vh. With gasoline in the tank and the system purged of air, start the motor and make a pressure gauge reading of the system pressure with the discharge valves closed; or, open one valve and calculate pumping rate.

Next, reverse power leads at L1 and L2. Repeat either pressure or flow tests, as described above. If results are higher than the first test, the rotation of the second test is correct. If the second test gives lower performance than the first, reconnect the power leads to L1 and L2 (as under test 1) for correct rotation.

Where the power supply has been properly marked L1, L2 and L3 in accordance with accepted phase rotation standards, it is possible to predetermine the proper rotation of these units. The motor power leads are color coded black, orange and red, and if connected through the magnetic starter to L1, L2 and L3 respectively, the motor pump unit will rotate in the correct direction. (See Fig. Vh.) It is recommended, however, that the performance tests always be made whether or not the power supply has been properly "phased out".

E. Starting the System and Completing the Installation

1. Do not start pumps unless ample product is in the storage tanks.
2. Pump sufficient product through each dispenser (150 gallons each is recommended) to purge the entire system of air. If all air is not purged, the computers may "creep" slightly when the dispenser switch is turned on, but no product has been dispensed.
3. On pumps equipped with built-in syphon, it is necessary to run the submerged pump at least 10 to 20 minutes continuously to purge the air from the syphon manifold.
4. After the above checks have been made, the backfill can be completed and the manholes installed as shown on Fig. VII.

F. Wiring instructions to retrofit an existing site - 208/240 volt, P200H1-2MB, single-phase pump with a new P200R1-2MB pump.

The following instructions apply only to replacing a P200H1 2MB pump with a P200R1-2MB pump. (See Fig. Va, Vb or Vc.)

1. **DISCONNECT** the power at the distribution panel prior to retrofitting an existing site.
2. The existing pigtail can be used with the new P200R1-2MB. However, if a new pigtail is needed, a new 3-wire conduit seal will be needed to replace the 5-wire conduit seal. The pin for this kit is part number 110-039-5.
3. Remove old UMP.
4. Install new UMP; insure the 4- bolt gaskets between the pigtail housing and the receptacle housing on the UMP are in place.
5. The two blue wires from the junction box up to the control box may be pulled through, or insulate the ends of them and leave them hanging.
6. The P200R1-2MB pump unit cannot be used with an existing P200H1-2MB control box. A retrofit kit must be installed into the existing enclosure. This can be done by disconnecting all the leads from the terminal strip and removing the existing metal plate to which all components (2-capacitors, a relay, contactor and overload protector) are mounted to and replacing it with a retrofit kit (part number 880-039-5). The new retrofit board contains one capaci-

tor, one terminal strip and one contactor. The hole in the cover must be covered with the label enclosed in the retrofit kit.

7. Connect the single-phase 208/240 volt power supply from the distribution panel to L1 and L2 to the terminal strip of the new retrofit board. Each control box should be wired through a separate fused disconnect switch or circuit breaker (including neutral, when used) furnished by the customer.
8. The magnetic contactor is shipped with the coil wired to accept 208-240 volts. No changes are required unless a 110-120 volt coil is desired. If so, rewire the coil per the wiring diagram label on the side of the contactor. **Disconnect** and remove the wire that connects terminal W and L2 of the contactor. **Connect a new wire** from terminal W to terminal NEU of the terminal strip. The neutral of the power supply must be brought in to terminal NEU. If an electronic dispenser is used, connect the "hot" from the dispenser to terminal 3.

NOTICE

3-wire control requires the use of an auxiliary contact in the magnetic contactor. This auxiliary contact is not standard equipment in the contactor supplied by Red Jacket, and must be ordered as an option. Use Furnas auxiliary field kit 49D22125001 or equivalent.

9. Connect the properly coded wires from the junction box of the submerged pump to the red, black and orange terminals of the terminal strip. Connect the two blue wires from the pump (if not pulled) to terminals BL2 and 3 of the terminal strip if 5-wire pigtail is used. If a 3-wire pigtail is used, the wires can be insulated and not connected to the terminal strip. Connect the wires from the dispenser control switches (if dispensers are used) and from the "on-off" switch at the loading rack; blue wires to terminal BL2 and black wires to terminal 3.
10. Reconnect the power at the distribution panel.

G. Wiring instructions for retrofitting an existing site, P200H3-2MB, P300H3-2HB, P500H3-2K, P300H17-3HB and P500H17-3K, pump units. The new pump units include the P200R4-2MB, P300R4-2HB and P500R4-2K, P300R17-3HB and P500R17-3K. The existing overload/heater combination cannot be used with the new umps listed above. (See Fig VI and Vm.)

1. **Disconnect** the power at the distribution panel prior to retrofitting the existing site.
2. The existing pigtail can be used with the new UMP. However, if a new pigtail is needed, a new 3-wire conduit seal will be needed to replace the existing 5-wire conduit seal. The pin for this kit is part number 110-039-5.
3. Remove old UMP.
4. Install new UMP; **insure** the 4-bolt gaskets between the pigtail housing and the receptacle housing on the UMP are in place.

5. **Disconnect** the red, black, and orange motor leads from T1, T2 and T3 of the overload in the magnetic starter.
6. **Disconnect** the 2 blue wires coming from the junction box. One connection will be at L3 and the other will be connected to the controlling "on-off" switch circuit.
7. **Connect a new wire** from L3 to where the other blue wire was connected to the controlling "on-off" switch circuit. This puts the contactor coil across the "on-off" controlling circuit.
8. The two blue wires from the junction box up to the magnetic starter may be pulled through, or insulate the ends of them and leave them hanging.
9. **Disconnect** the red wire from the contactor coil terminal. This is the wire coming from the overload/heater unit.
10. **Disconnect** the black wire from the overload/heater unit and connect it to the open contactor coil terminal.
11. **Remove** the three screws from the contactor that connect it to the overload/heater unit.
12. **Remove** the one screw at the base of the overload/heater unit.
13. **Remove** the overload/heater unit.
14. **Reconnect** the motor leads from the junction box to the contactor using the three screws removed in Step 11.
15. **Reconnect** the power at the distribution panel.
16. Check for proper rotation of the motor as stated in section C.

H. Wiring instructions for retrofitting an existing site, 575-volt, P500H6-2K, three-phase pump, with a new P500R6-2K pump unit.

1. **Disconnect** the power at the distribution panel prior to retrofitting the existing site.
2. The existing pigtail can be used with the new P500R6-2K pump unit.
3. Remove old UMP.
4. Install new UMP; **insure** the 4-bolt gaskets between the pigtail housing and the receptacle housing on the UMP are in place.
5. Remove the existing three K41 heaters from the overload of the magnetic starter.
6. Insert three K49 heaters (part number 036-073-1) in the overload of the magnetic starter.
7. Reconnect power at the distribution panel.
8. Check for proper motor rotation as stated in section D.

P200R1, 208-240V, 2 HP SINGLE PHASE

WARNING The control box must be grounded for personal safety. Refer to the National Electrical Codes and applicable local codes for proper grounding procedures.

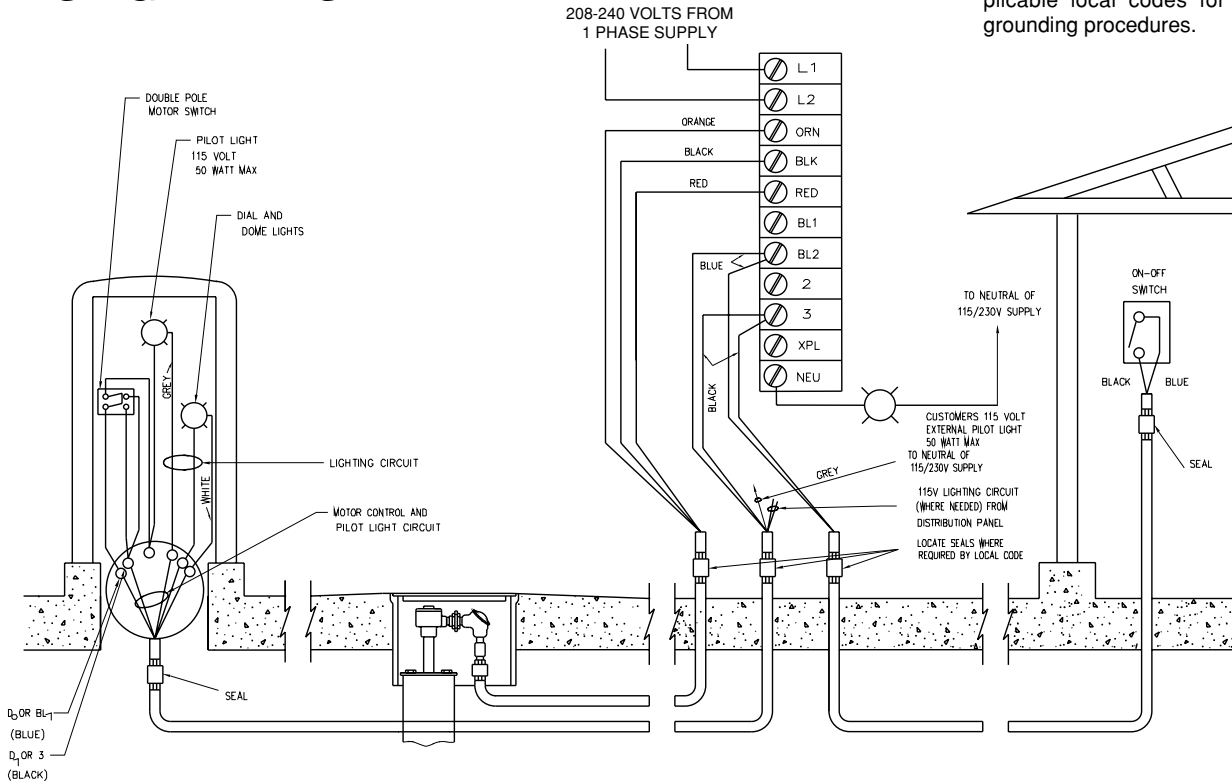

**TYPICAL MECHANICAL DISPENSER
P200R1 REPRESENTATIVE WIRING DIAGRAM, 1Ø , TWO-WIRE CONTROL**

Fig. Va

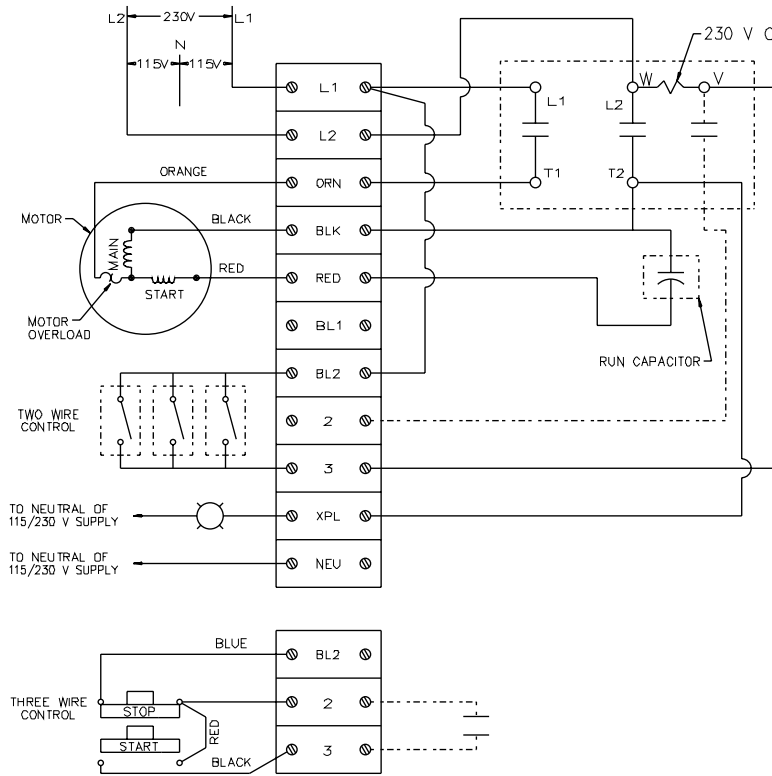

NOTE: APPROVED COMPONENT ONLY - TOTAL SYSTEM INSTALLED SHALL COMPLY WITH ALL LOCAL CODES.

P200R1, 208-240, 2HP 1Ø Control Box

MAKE GROUND CONNECTION IN ACCORDANCE WITH LOCAL CODES

WARNING The control box must be grounded for personal safety. Refer to the National Electrical Codes and applicable local codes for proper grounding procedures.

NOTICE 3-wire control requires the use of an auxiliary contact in the magnetic contactor. Furnas auxiliary interlock field kit 49D22125001 or equivalent.

**TYPICAL MECHANICAL DISPENSER
P200R1 MOTOR CONTROL BOX, WIRING DIAGRAM, 2 H.P.**

Fig. Vb

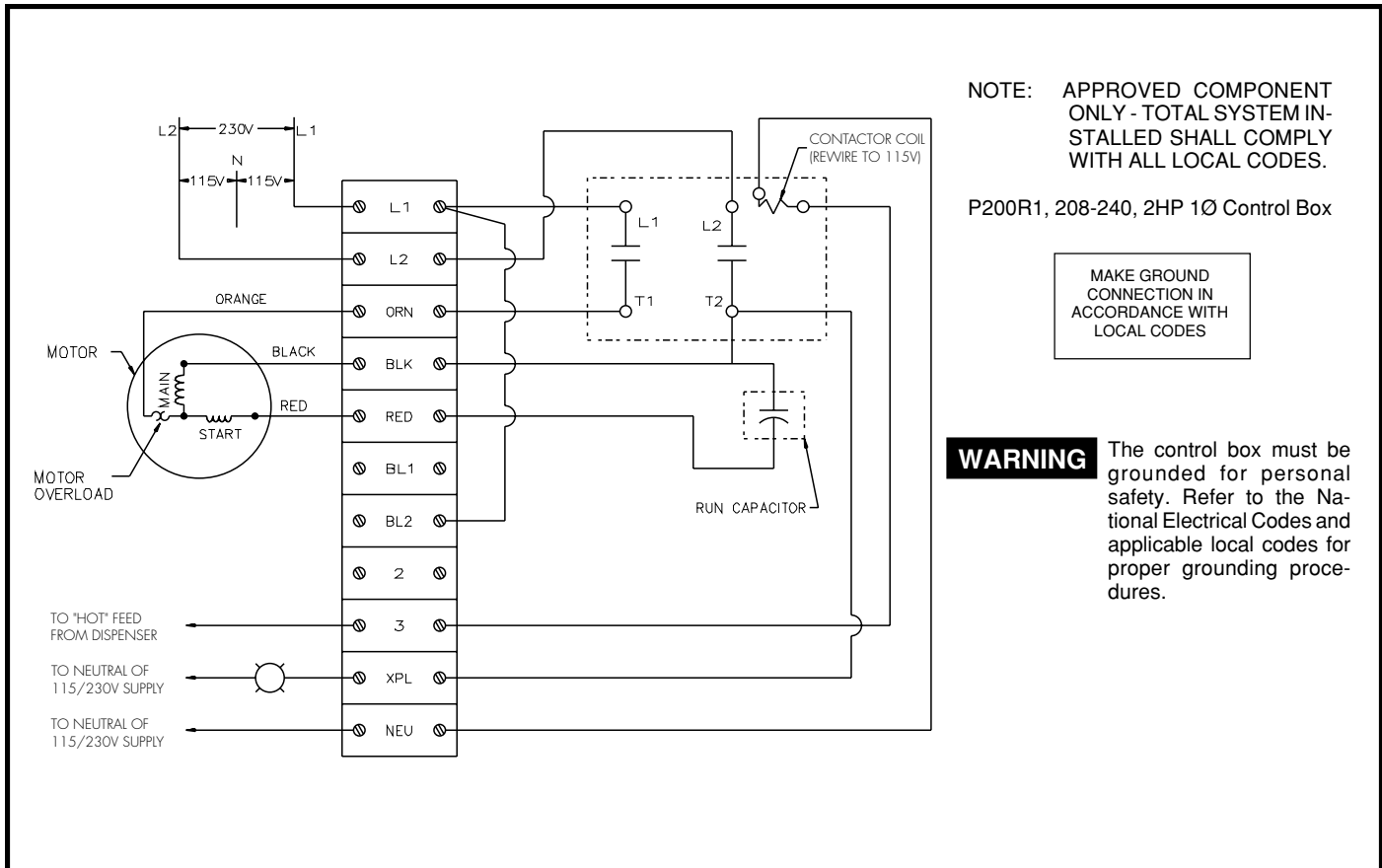

NOTE: APPROVED COMPONENT ONLY - TOTAL SYSTEM INSTALLED SHALL COMPLY WITH ALL LOCAL CODES.

P200R1, 208-240, 2HP 1Ø Control Box

MAKE GROUND CONNECTION IN ACCORDANCE WITH LOCAL CODES

WARNING The control box must be grounded for personal safety. Refer to the National Electrical Codes and applicable local codes for proper grounding procedures.

REPRESENTATIVE WIRING DIAGRAM FOR USE WITH SWITCHED "HOT" FEED P200R1, 208-240 VOLTS A.C., 2 HP SINGLE-PHASE CONTROL BOX.

Fig. Vc

NOTICE If 115V is not available from power supply, pilot lights may be operated from any 115V lighting circuit by controlling with a 4-pole starter. Otherwise, 230V pilot lights must be used.

WARNING The control box must be grounded for personal safety. Refer to the National Electrical Codes and applicable local codes for proper grounding procedures.

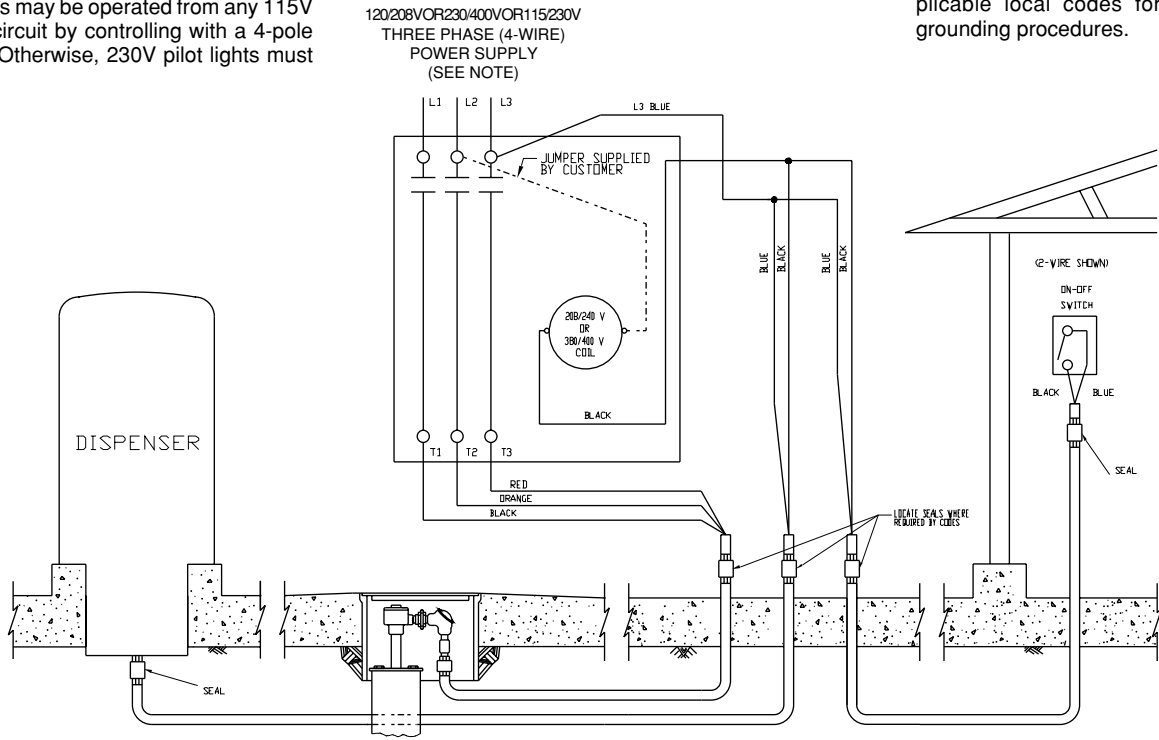

TYPICAL MECHANICAL DISPENSER REPRESENTATIVE WIRING DIAGRAM, 3Ø, TWO-WIRE CONTROL

Fig. Vd

280/230V OR 400V, 3-PHASE
POWER SUPPLY

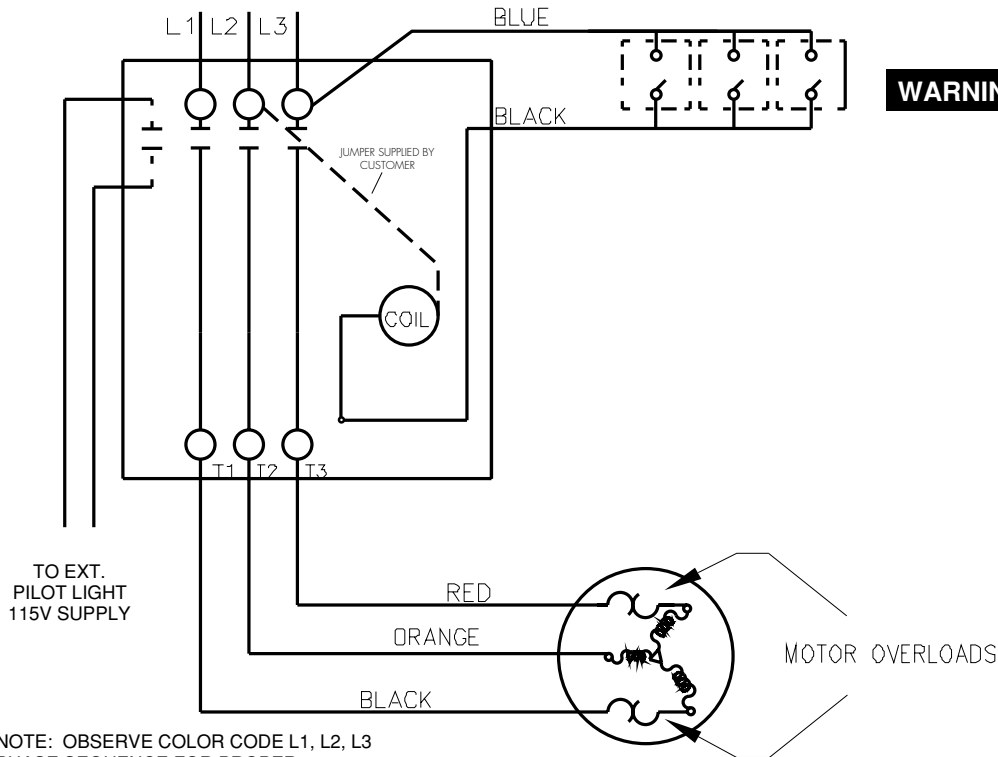

WARNING

The control box must be grounded for personal safety. Refer to the National Electrical Codes and applicable local codes for proper grounding procedures.

NOTE: OBSERVE COLOR CODE L1, L2, L3
PHASE SEQUENCE FOR PROPER
ROTATION OF MOTOR.

**400V OR 208/230V, THREE-PHASE POWER SUPPLY
TWO-WIRE CONTROL, THREE-PHASE MOTOR WIRING DIAGRAM**

Fig. Ve

208/230V OR 400V, 3 PHASE
POWER SUPPLY

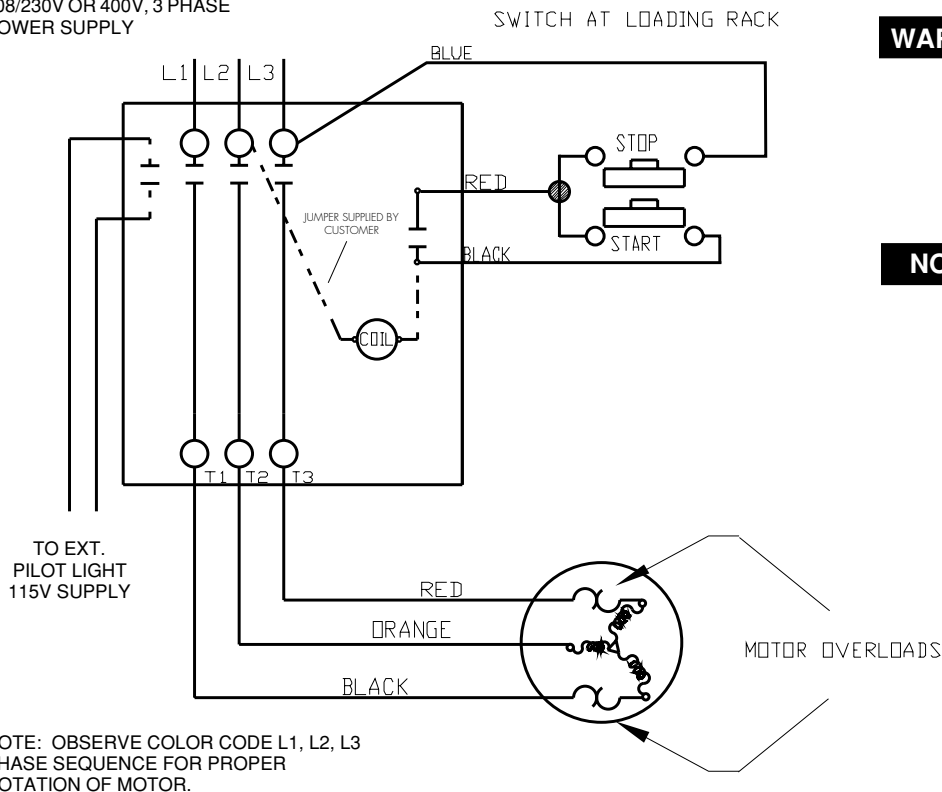

WARNING

The control box must be grounded for personal safety. Refer to the National Electrical Codes and applicable local codes for proper grounding procedures.

NOTICE

3-wire control requires the use of an auxiliary contact in the magnetic contactor. Furnas auxiliary interlock field kit 49D22125001 or equivalent.

NOTE: OBSERVE COLOR CODE L1, L2, L3
PHASE SEQUENCE FOR PROPER
ROTATION OF MOTOR.

**400V OR 208/230V, THREE-PHASE POWER SUPPLY
THREE-WIRE CONTROL, THREE-PHASE MOTOR WIRING DIAGRAM**

Fig. Vf

WARNING

The control box must be grounded for personal safety. Refer to the National Electrical Codes and applicable local codes for proper grounding procedures.

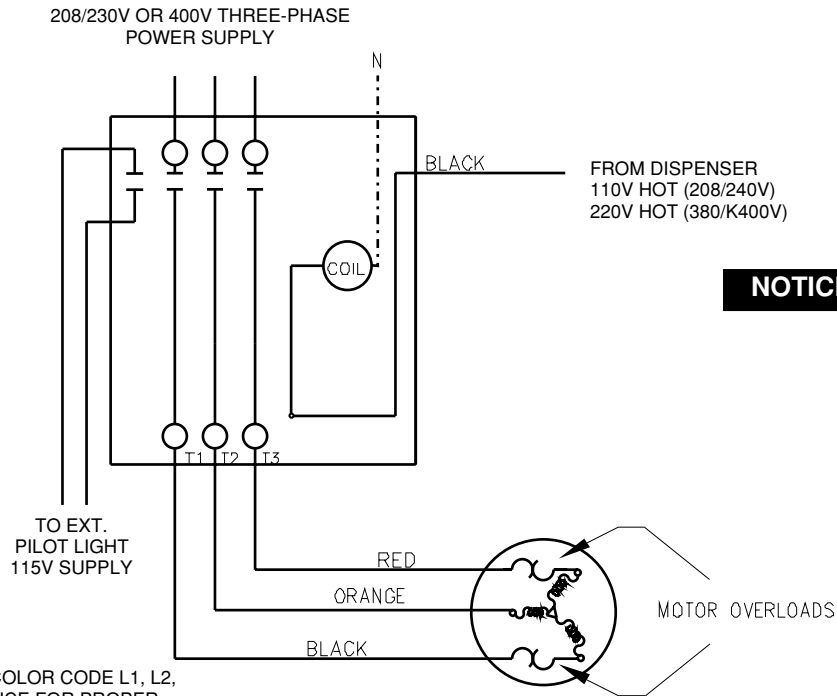

NOTICE

Rewire coil for proper voltage.

NOTE: OBSERVE COLOR CODE L1, L2, L3 PHASE SEQUENCE FOR PROPER ROTATION OF MOTOR

400V OR 208/230V, THREE-PHASE POWER SUPPLY SWITCHED "HOT" FEED

Fig. Vg

WARNING

The control box must be grounded for personal safety. Refer to the National Electrical Codes and applicable local codes for proper grounding procedures.

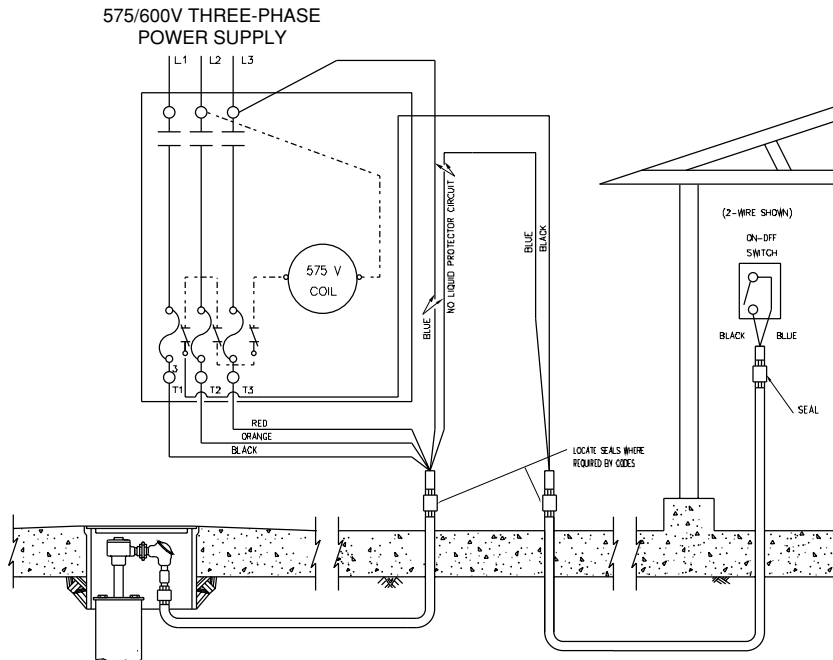

NOTICE

If 115V is not available from power supply, pilot lights may be operated from any 115V lighting circuit by controlling with a 4-pole starter. Otherwise, 575V pilot lights must be used.

REPRESENTATIVE WIRING DIAGRAM, THREE-PHASE, TWO-WIRE CONTROL

Fig. Vh

WARNING The control box must be grounded for personal safety. Refer to the National Electrical Codes and applicable local codes for proper grounding procedures.

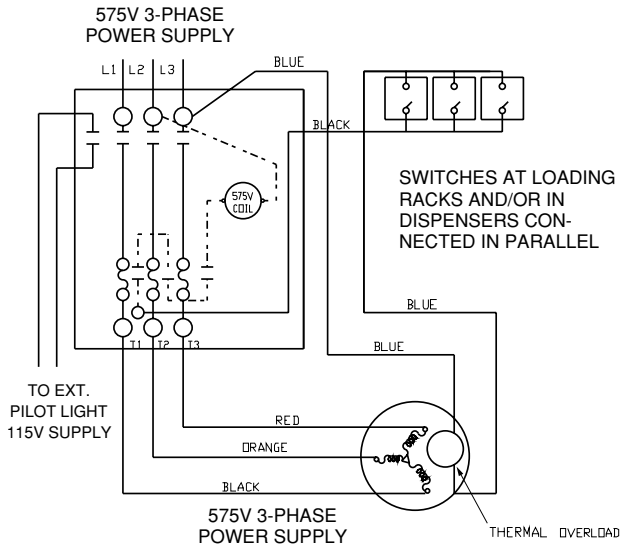

NOTE: OBSERVE COLOR CODE L1, L2, L3 PHASE SEQUENCE FOR PROPER ROTATION OF MOTOR

TWO WIRE THREE-PHASE MOTOR WIRING DIAGRAM

Fig. Vi

WARNING The control box must be grounded for personal safety. Refer to the National Electrical Codes and applicable local codes for proper grounding procedures.

NOTICE Rewire coil for proper voltage.

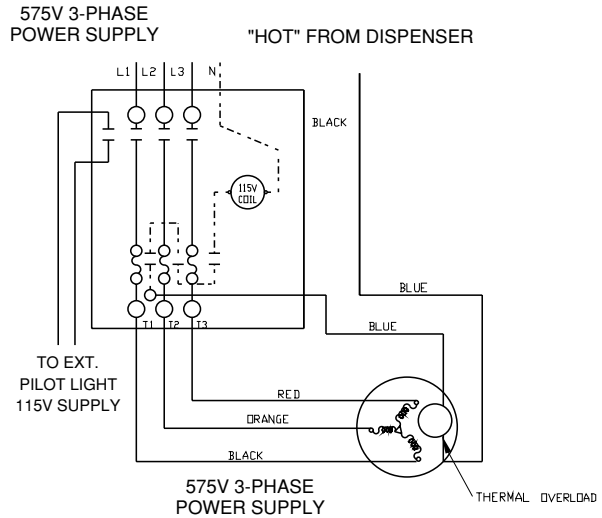

NOTE: OBSERVE COLOR CODE L1, L2, L3 PHASE SEQUENCE FOR PROPER ROTATION OF MOTOR

THREE-PHASE MOTOR WIRING DIAGRAM

Fig. Vk

575/600V THREE-PHASE POWER SUPPLY

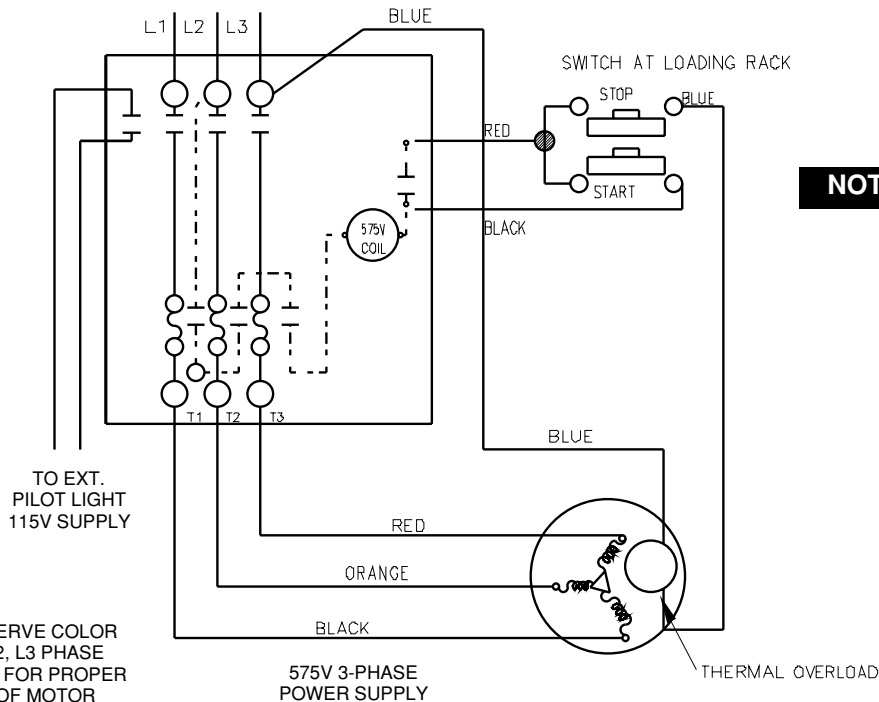

NOTE: OBSERVE COLOR CODE L1, L2, L3 PHASE SEQUENCE FOR PROPER ROTATION OF MOTOR

THREE WIRE THREE-PHASE MOTOR WIRING DIAGRAM

Fig. Vj

WARNING The control box must be grounded for personal safety. Refer to the National Electrical Codes and applicable local codes for proper grounding procedures.

NOTICE 3-wire control requires the use of an auxiliary contact in the magnetic starter. Furnas interlock kit or 49D22125001 or equivalent.

NOTICE

If 115V is not available from power supply, pilot lights may be operated from any 115V lighting circuit by controlling with a 4-pole starter. Otherwise, 230V pilot lights must be used.

WARNING

The control box must be grounded for personal safety. Refer to the National Electrical Codes and applicable local codes for proper grounding procedures.

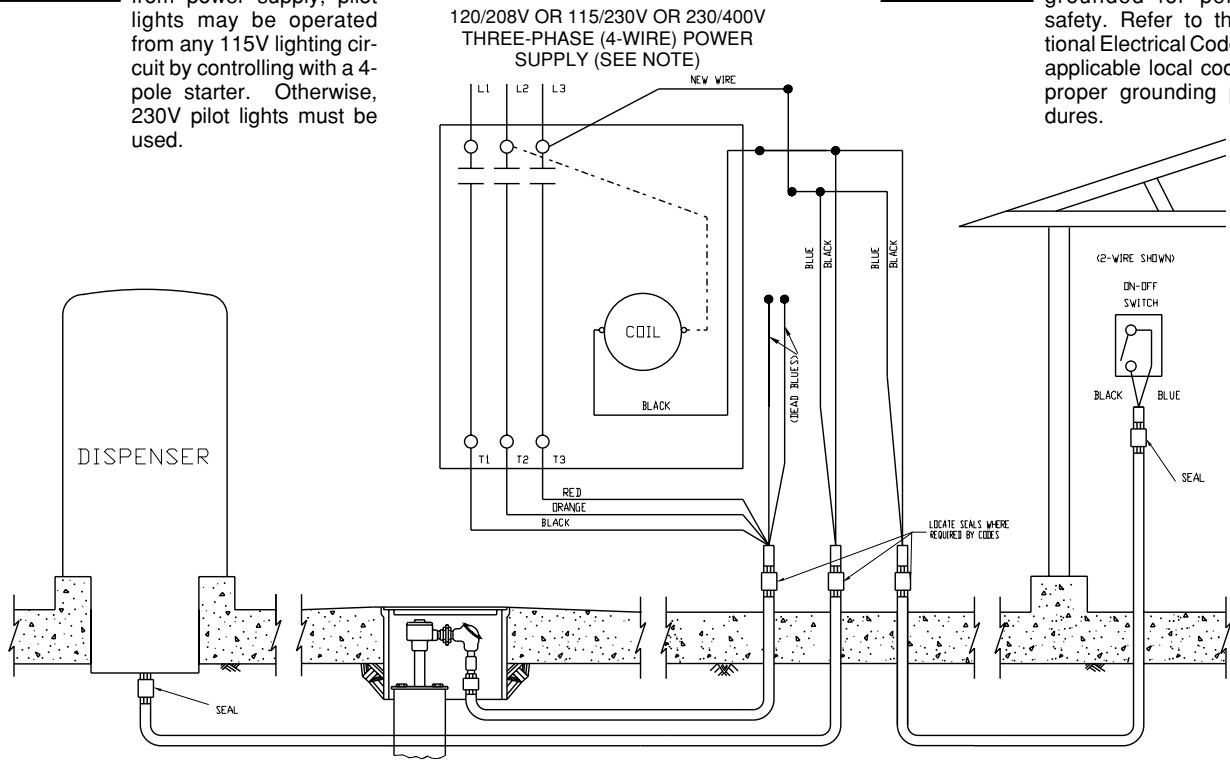

REPRESENTATIVE RETROFIT WIRING DIAGRAM, 3Ø, TWO-WIRE CONTROL

Fig. VI

WARNING

The control box must be grounded for personal safety. Refer to the National Electrical Codes and applicable local codes for proper grounding procedures.

NOTICE

Rewire coil for proper voltage.

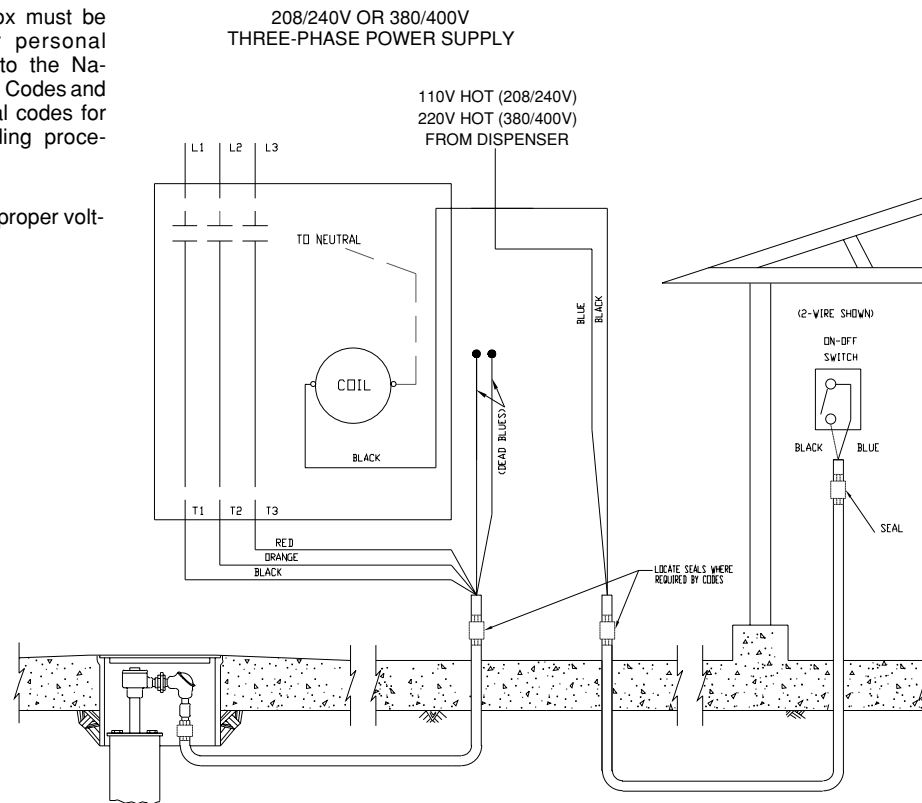

TYPICAL ELECTRONIC DISPENSER RETROFIT WIRING DIAGRAM, 3Ø, TWO-WIRE CONTROL

Fig. Vm

BIG-FLO® LEAK DETECTOR SUGGESTED INSTALLATIONS MANIFOLD DIMENSIONS

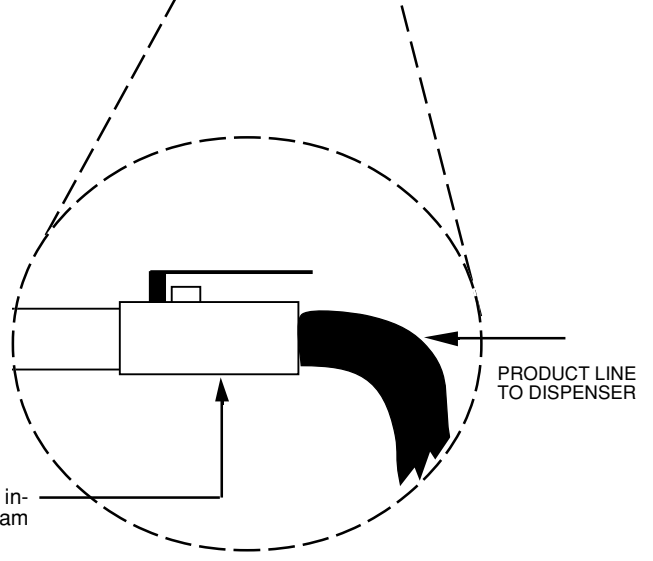
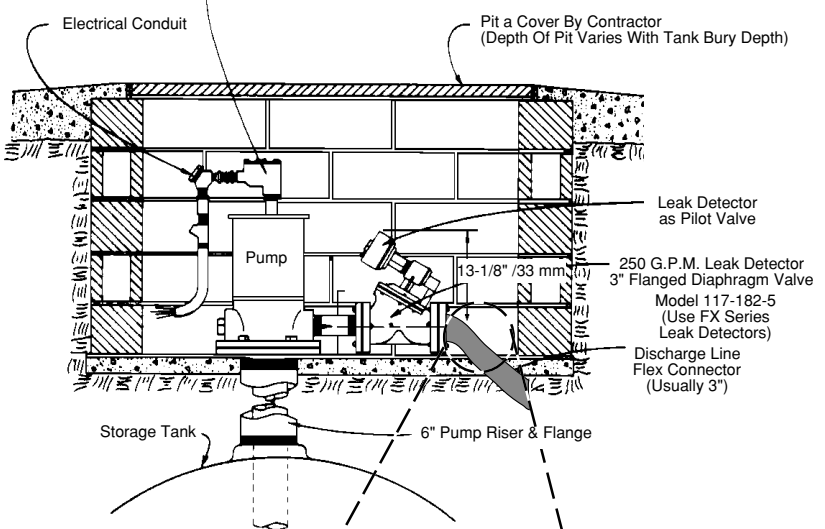
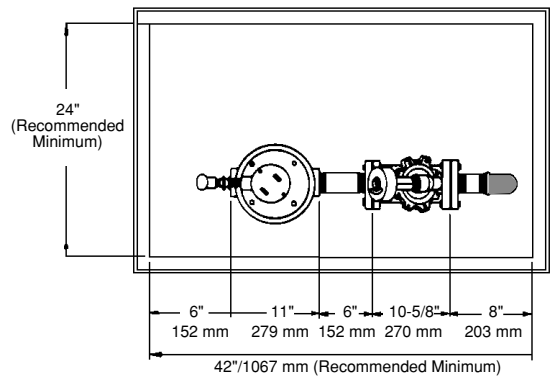
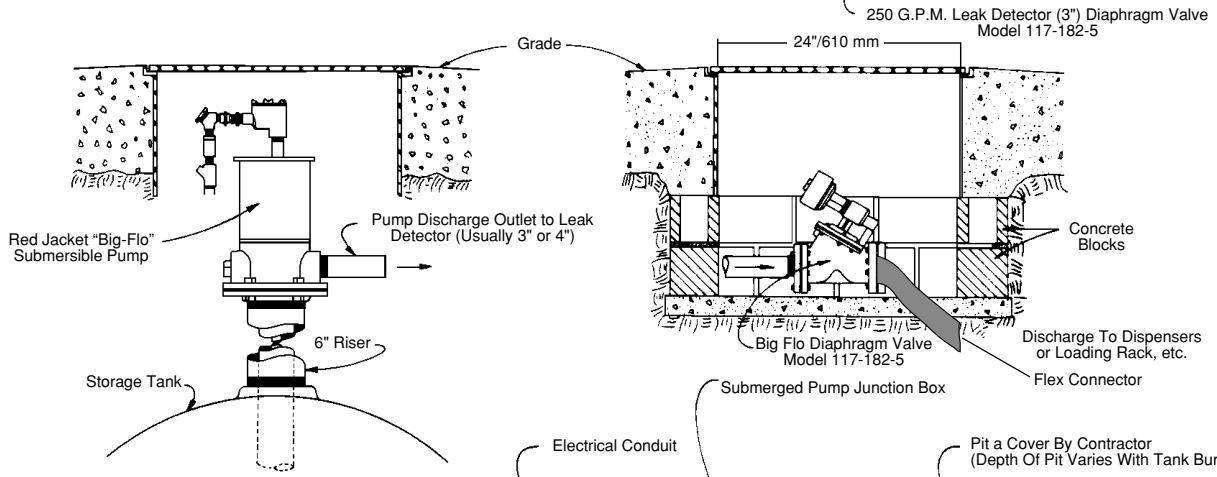
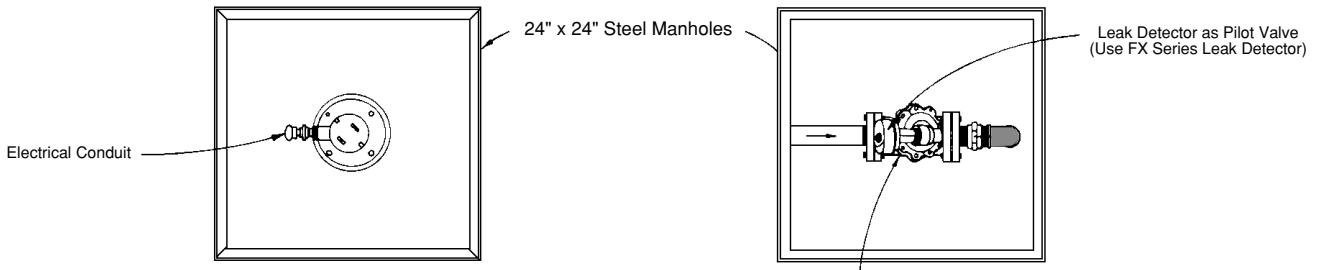

As an option in troubleshooting, install a BALL VALVE downstream from the discharge of the pump.

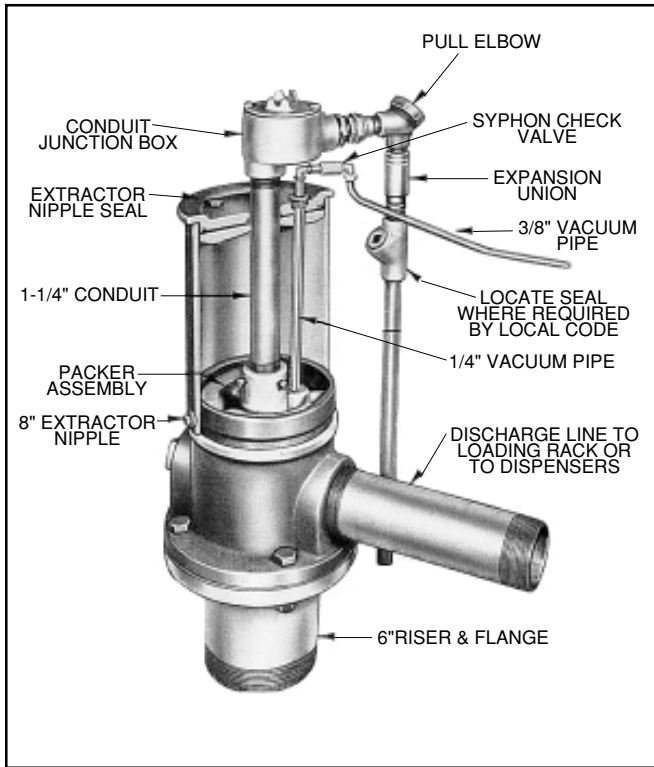
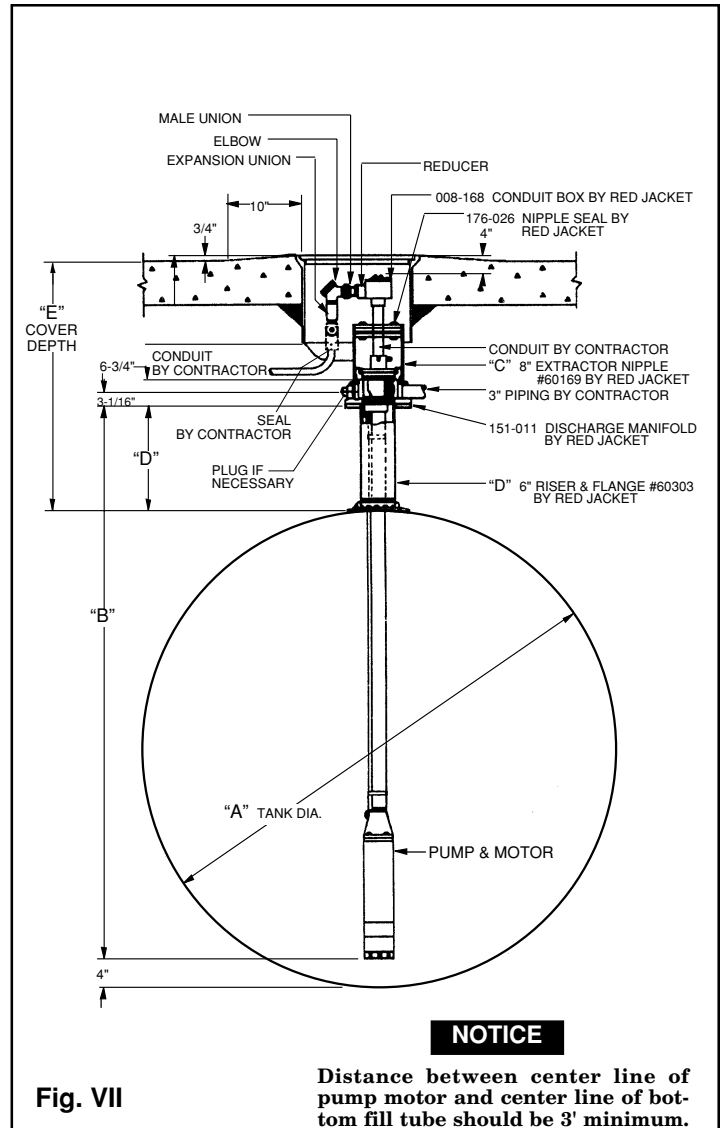

Fig. VI



NOTICE

Distance between center line of pump motor and center line of bottom fill tube should be 3' minimum. Air locking of pump may occur at distances less than this distance.

NOTICE Use table below for single wall steel tank applications only.

Example: A 10'-6" diameter tank buried 3'-0" will require a 10'-6" long pump, 4" long riser & 16" long extractor nipple.

TABLE OF PUMP RISER & EXTRACTOR NIPPLE LENGTHS FOR VARIOUS TANK DIAMETERS & VARIOUS BURY DEPTHS												
Diameter Storage Tank "A"	5'-4"	6'-0"	6" 3-1/2"	7'-0"	7'-6"	8'-0"	8' 3-1/2"	9'-0"	10'-0"	10'-6"	11'-0"	12'-0"
Pump Length "B"	5'-3"	6'-3"	6'-3"	7'-3"	8'-3"	8'-3"	8'-3"	9'-3"	10'-7"	10'-7"	11'-3"	12'-3"
Riser Length "D"	5"	7"	4"	7"	13"	7"	4"	7"	11"	5"	7"	7"
Extractor Nipple "C" Length When Tank is Covered:												
2'-0" Bury	5"	5"	5"	5"	5"	5"	5"	5"	5"	5"	5"	5"
2'-6" Bury	10"	7"	10"	7"	5"	7"	10"	7"	5"	10"	7"	7"
3'-0" Bury	16"	13"	16"	13"	7"	13"	16"	13"	10"	16"	13"	13"
3'-6" Bury	22"	19"	22"	19"	13"	19"	22"	19"	16"	22"	19"	19"
4'-0" Bury	28"	25"	28"	25"	19"	25"	28"	25"	22"	28"	25"	25"

* Pump length for 2' bury will be 7'7" long with a 5" riser length.

** 5" nipple not required.

WARNING A variety of tank types with various materials of construction are currently in use. The inside diameter, (I.D.) which is critical to determining correct pump length, can differ appreciably though outside diameters may be similar. Red Jacket Pumps are built to order to accommodate individual tank and bury depth requirements. Accurate tank and site measurements are critical to achieve the proper pump length and avoid damage to the pump or tank which can result in substantial property damage, personal injury or death. Petro Express Bulletin RJ 23-25 explains the information required for proper pump sizing.

HEAD EQUIVALENTS	
1 PSI	= 2.31 Feet of Water
	= 3.2 Feet Gasoline (.72 Sp. Gr.)
	= 2.9 Feet Kerosene (.80 Sp. Gr.)
	= 2.6 Feet Heating Oil (.89 Sp. Gr.)

TYPICAL SYPHON SYSTEM

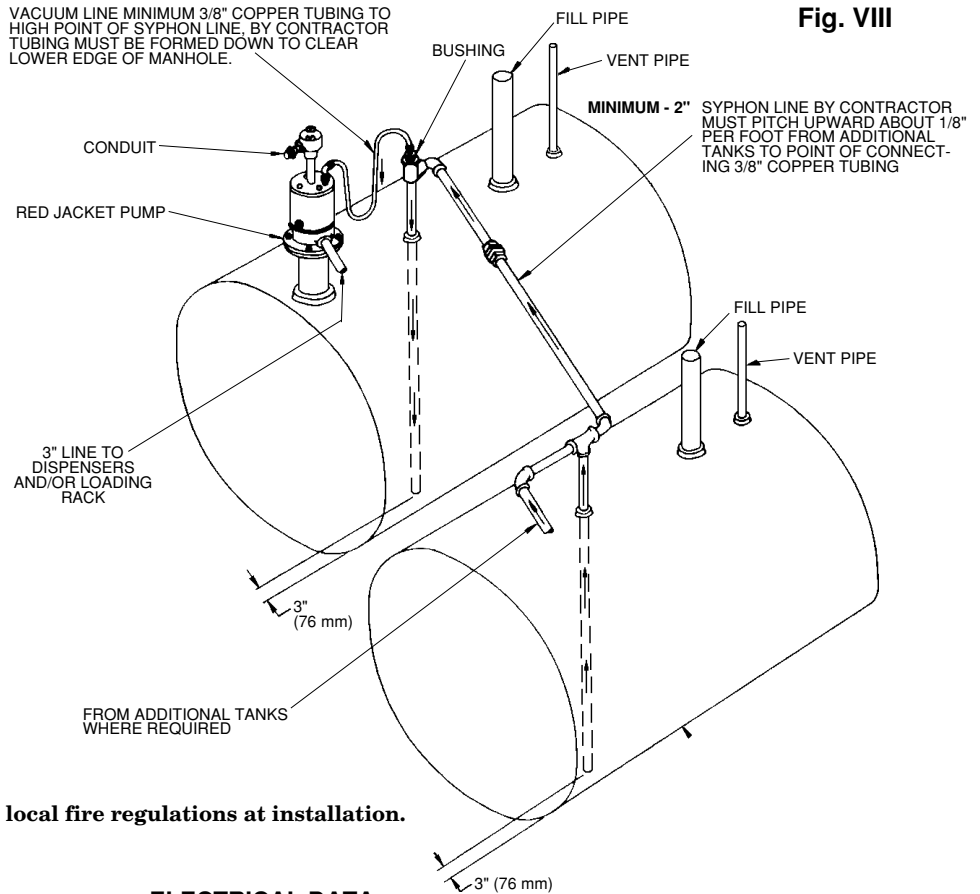

Fig. VIII

NOTICE All piping must conform to local fire regulations at installation.

ELECTRICAL DATA

Model Number Pump Motor Assembly	HP	Volt	Phase	Winding Resistances (OHMS)			
				Orange to Red	Orange to Blk	Red to Blk	Blue to Blue
UMP200R1-2MB	2	208-240	1	2.6-3.1	1.4-2.1	4.0-4.8	—
UMP200R4-2MB	2	208-240	3	2.2-2.7	2.2-2.7	2.2-2.7	—
UMP300R4-2HB	3	208-240	3	1.5-1.8	1.5-1.8	1.5-1.8	—
UMP300R17-3HB	3	380-415	3	6.0-7.1	6.0-7.1	6.0-7.1	—
UMP500R4-2K	5	208-240	3	0.8-1.0	0.8-1.0	0.8-1.0	—
UMP500R17-3K	5	380-415	3	3.0-3.7	3.0-3.7	3.0-3.7	—
UMP500R6-2K	5	575	3	5.4-6.6	5.4-6.6	5.4-6.6	0.0-1.0

NOTICE The above readings do not include the added resistance of the power supply wires to the submersible pump. Therefore, in order for the readings to fall within the above limits, the resistance should be checked at the submersible pump junction box. If the resistance readings are taken at the control box or magnetic starter, they will be slightly higher.

DANGER Always make a complete power disconnect before taking resistance readings.

RECOMMENDED FLOATING SUCTION INSTALLATION

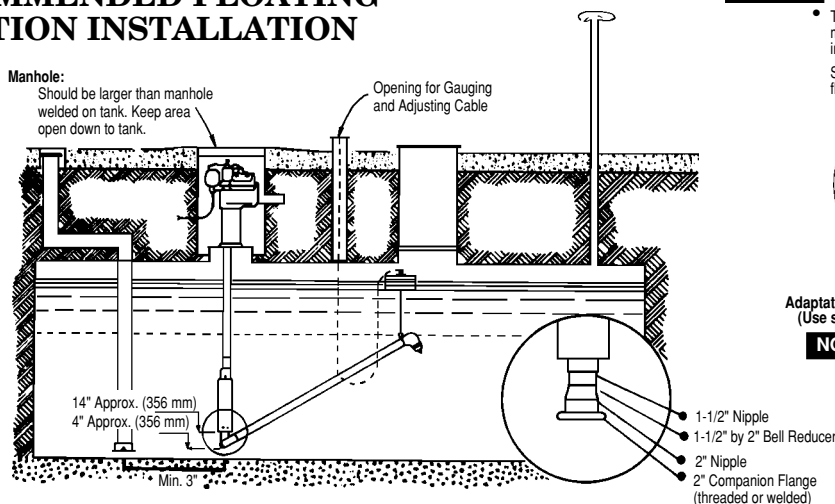

NOTICE We supply adapter only; not the apparatus.

- The floating suction arm can be mounted to pump previous to installing in tank. See example of adaptation to floating suction assembly below.
- Easy service access is provided by unbolting manhole lid through which pump is mounted and removing entire assembly.

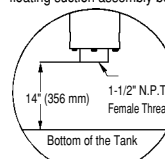

4" Petroleum Adapter

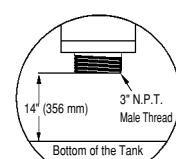

6" Petroleum Adapter

Adaptation to Floating Suction Assembly
(Use standard NPT threaded fittings).

NOTICE Use proper thread sealant and insert gasket between flanges of floating suction and pump. This prevents hindrance to pump performance when product level is below this point.

Red Jacket petroleum and solvent pumps are centrifugal type pumps and as such are not designed to pump product when the level is below the bottom end of the pump/motor assembly.

**ELECTRICAL DATA
(continued)**

HP	Volts	Phase	Service	Locked	Branch Ckt. Protection		Wire Size for Max Length of Run Shown (From Service Entrance to Pump in Feet)					NEMA Codes
			Factor Cur. (Amps)	Rotor Cur. (Amps)	Fusetron (Amps)	Ckt. Brkr. (Amps)	No. 14	No. 12	No. 10	No. 8	No. 6	
2	208-240*	1	14.0	59.0	20	20	—	235	365	575	895	G
2	208-240*	3	9.0	41.0	15	15	295	470	740	1160	1810	J
3	208-240*	3	11.8	65.0	20	20	275	360	565	885	1380	K
3	380-415	3	6.2	30.0	15	15	730	1160	1820	2855	—	K
5	208-240*	3	19.0	95.0	25	30	—	235	365	575	900	J
5	380-415	3	9.5	45.0	15	15	465	740	1155	1820	2830	G
5	575	3	7.6	44.8	15	15	925	1470	2305	3615	—	K

* Figures represent maximum length in feet for 220 or 230 volt system. Use 75% of length for 208 volt systems.

INSTALLING DUAL SUBMERSIBLES MANIFOLDED IN THE SAME SYSTEM

This type of system is often used when greater flow rates are needed. If installed according to the illustration below (Fig. XIa), manifolded systems offer back-up support in that operations could continue should one unit fail.

WARNING

The check valves shown installed in the discharge line of each pump are necessary to prevent product from being pumped through the pressure relief system of the adjacent pump, if that pump is not running. This is because the expansion relief valve

operates at below pump pressures. If check valves without pressure relief were used, there would be no provision for thermal expansion between the valves and the dispensers.

It is preferable that the wiring allow both submersibles to operate simultaneously with any combination of dispensers turned on. To operate individually, the appropriate disconnect switch must be turned off manually. (See figures XIb through XIg for suggested wiring diagrams.)

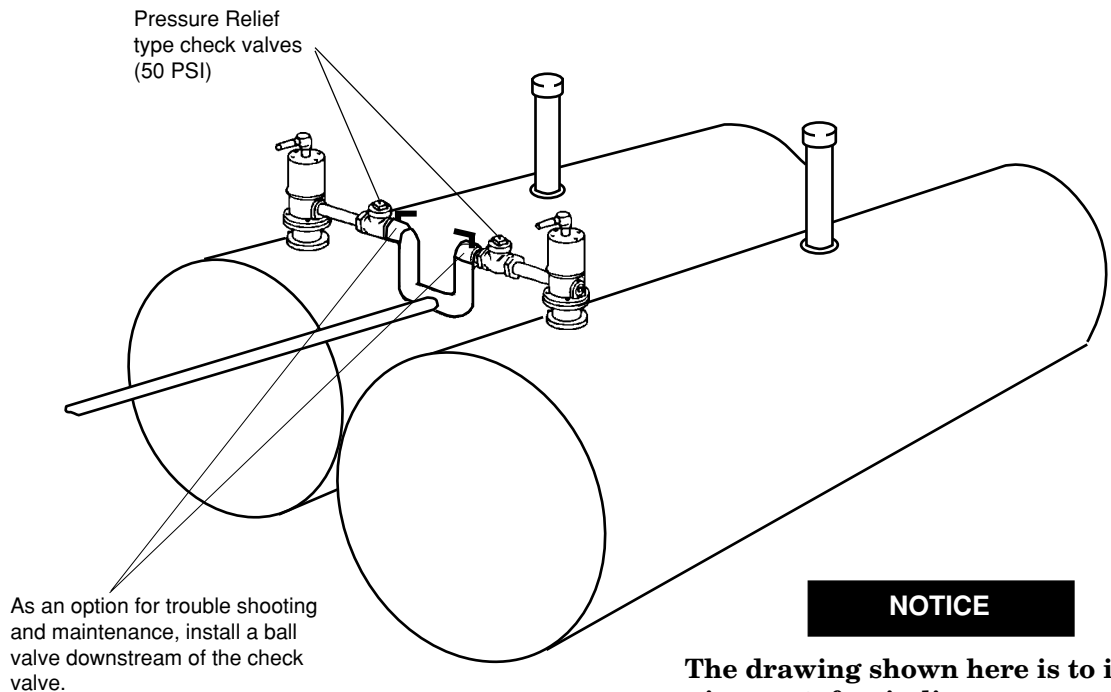

The drawing shown here is to illustrate the requirement for in-line, pressure relief type check valves. It is not a recommended guide for installation of piping downstream of the check valves.

Fig. IXa

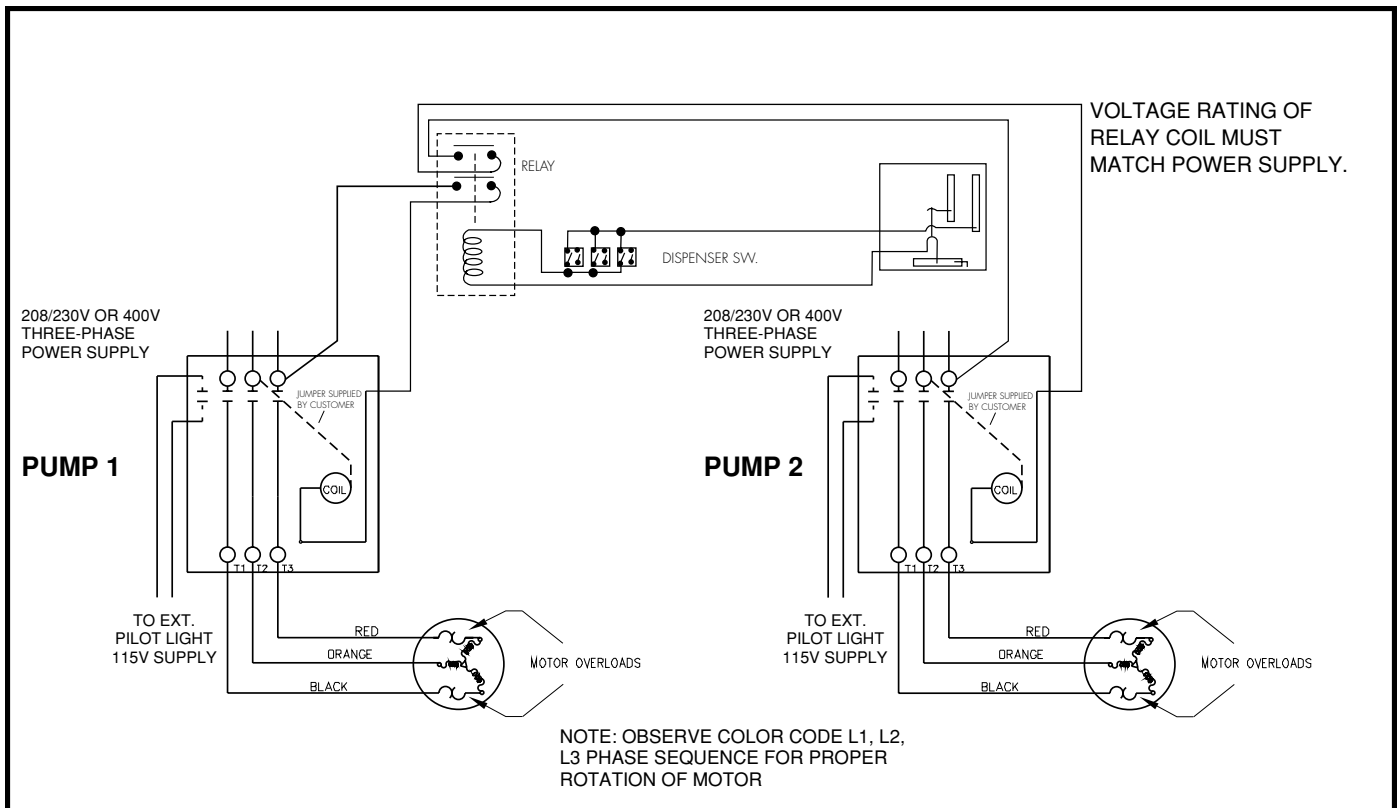

**SUGGESTED DIAGRAM FOR WIRING DUAL MANIFOLD SYSTEM.
TWO WIRE CONTROL. 208-240V OR 400V THREE PHASE**

Fig. IXd

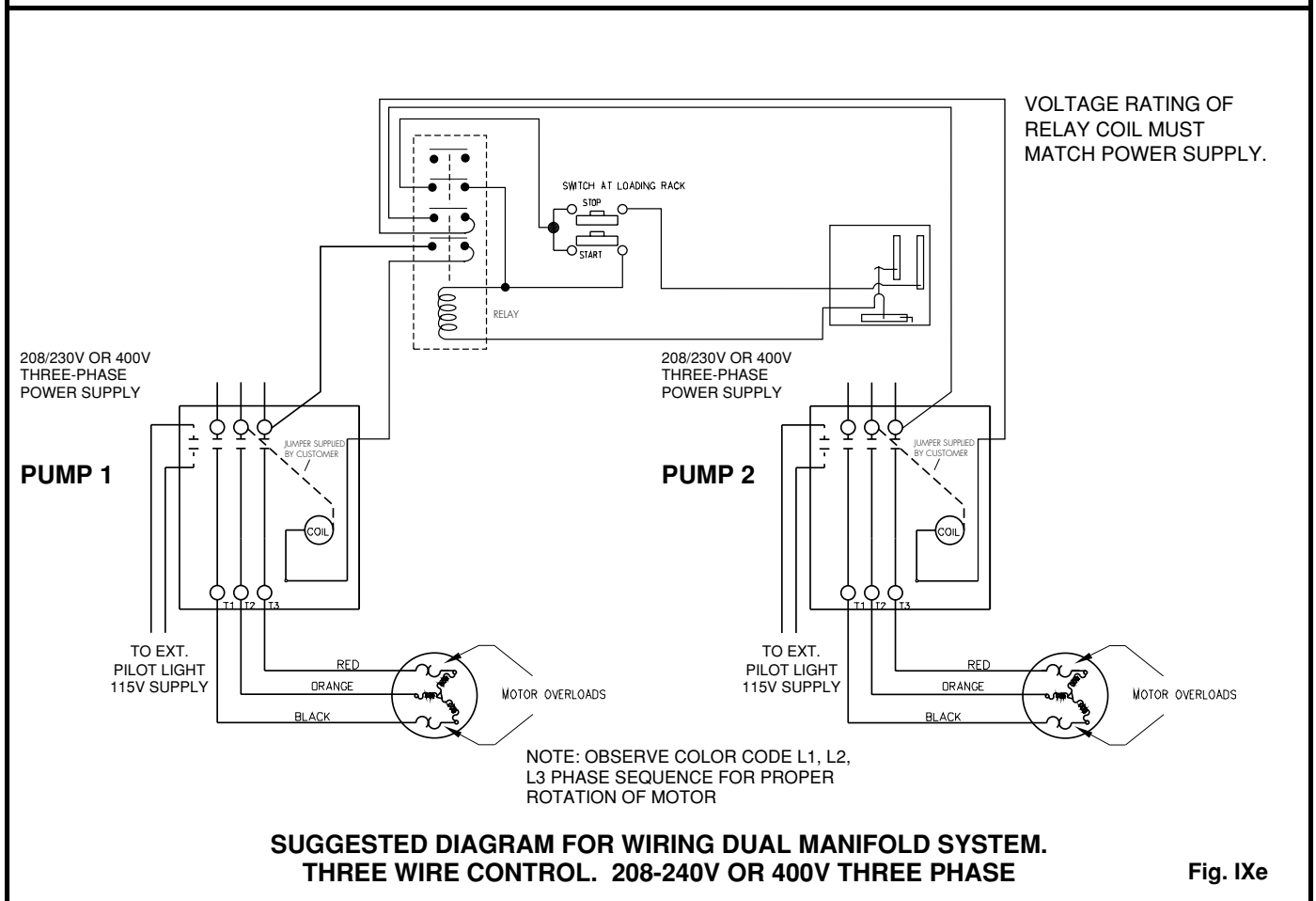

**SUGGESTED DIAGRAM FOR WIRING DUAL MANIFOLD SYSTEM.
THREE WIRE CONTROL. 208-240V OR 400V THREE PHASE**

Fig. IXe

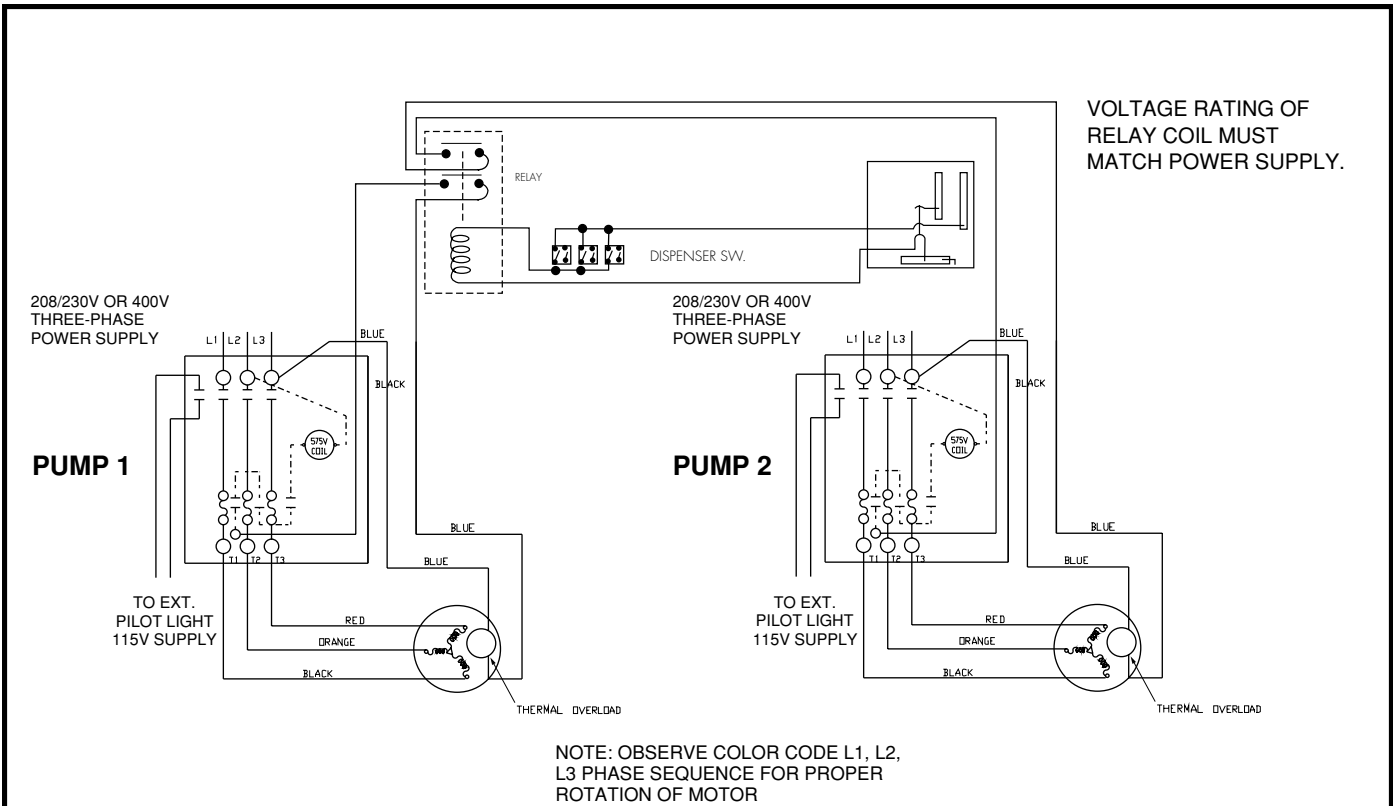

VOLTAGE RATING OF RELAY COIL MUST MATCH POWER SUPPLY.

SUGGESTED DIAGRAM FOR WIRING DUAL MANIFOLD SYSTEM. THREE WIRE CONTROL. 575V THREE PHASE

Fig. IXf

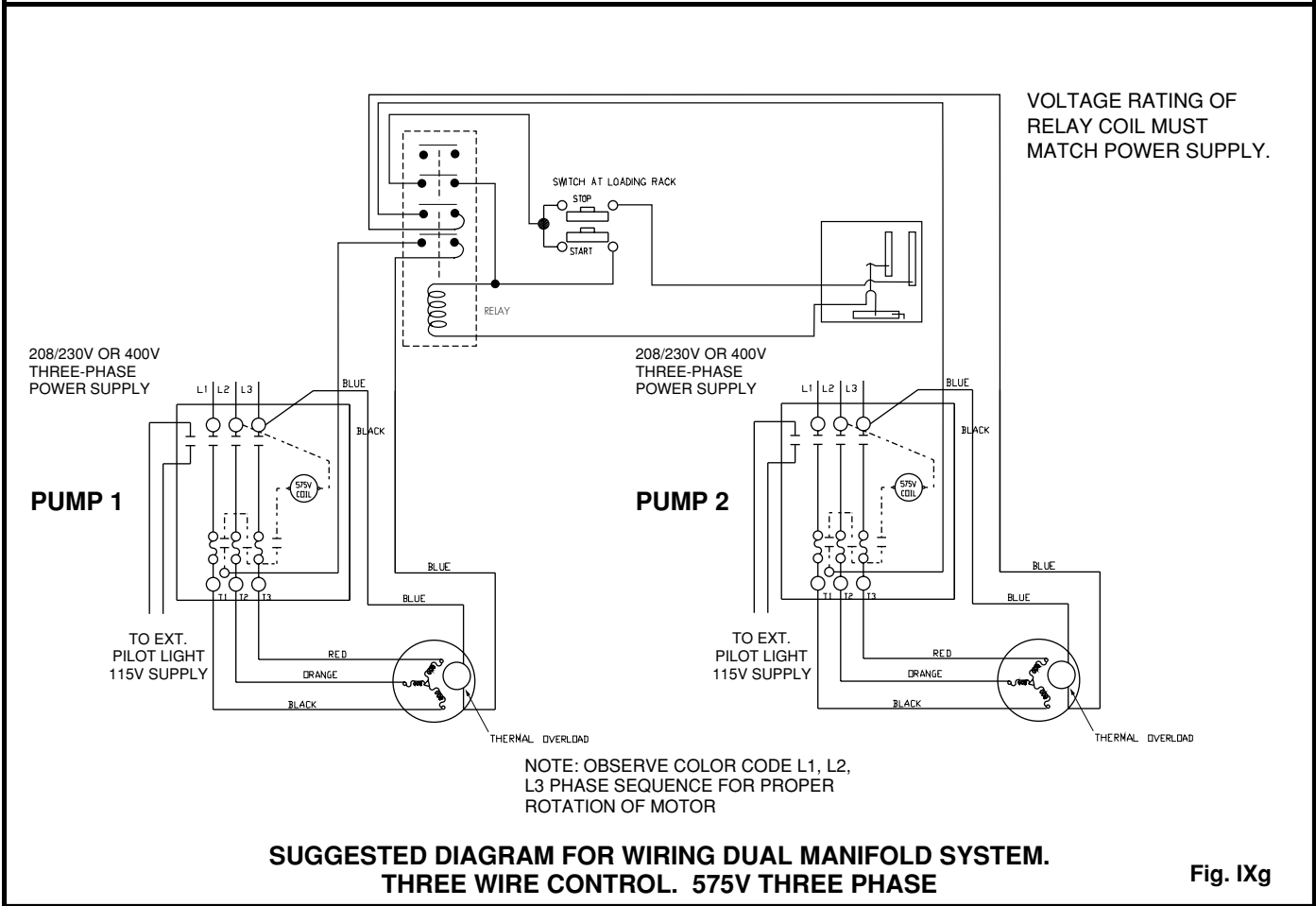

VOLTAGE RATING OF RELAY COIL MUST MATCH POWER SUPPLY.

SUGGESTED DIAGRAM FOR WIRING DUAL MANIFOLD SYSTEM. THREE WIRE CONTROL. 575V THREE PHASE

Fig. IXg

REPAIR PARTS LIST – PACKER ASSEMBLY

(Packer Assembly is the same on All Model Big-Flo® Pumps)

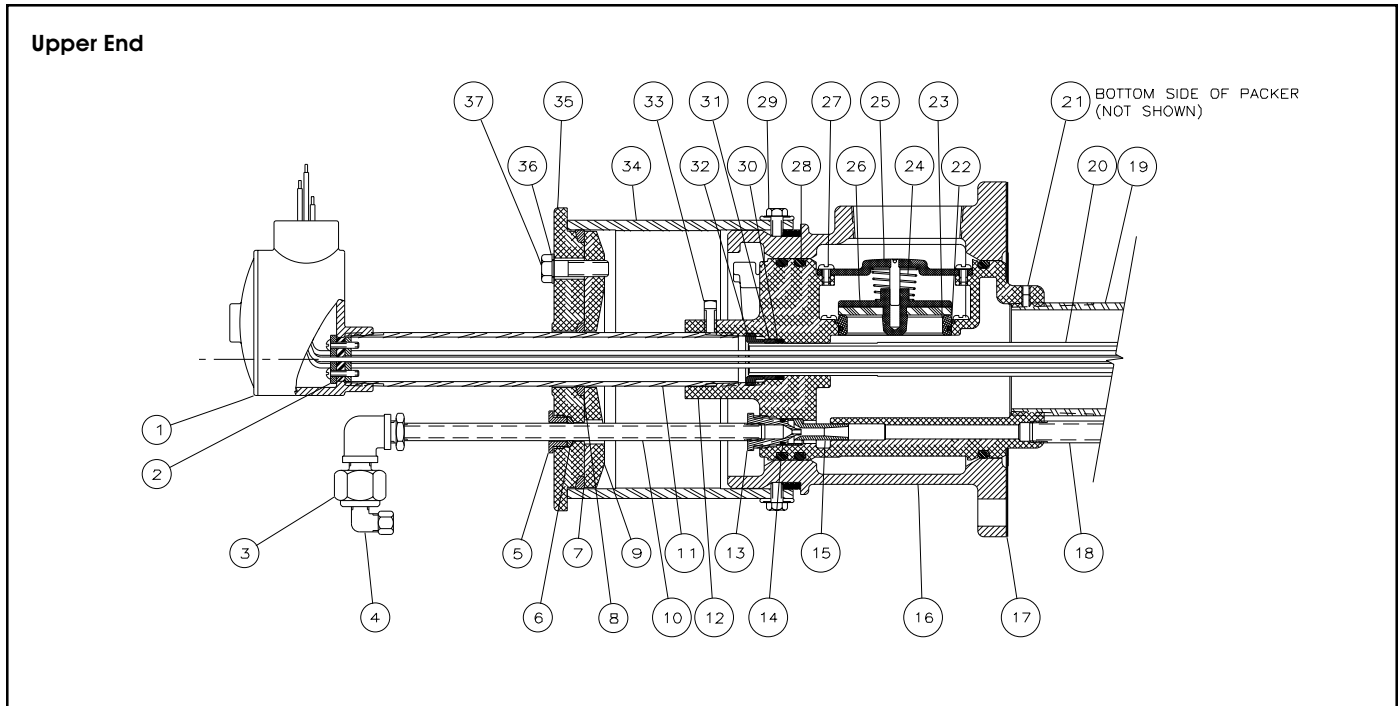

Item	Part No.	Description	No. Req'd.
1	008-168-1	Conduit Junction Box	1
2	110-038-5	Conduit Seal Assembly — 5-wire	1
2	110-039-5	Conduit Seal Assembly — 3-wire	1
3	188-241-5	Syphon Check Valve	1
4	288-056-4	Syphon Check Valve Assembly	1
5	060-048-1	Packing Nut Syphon Tube	1
6	031-097-1	Syphon Pipe Gasket	1
7	031-106-1	Extractor Nipple Gasket — Outer	1
8	031-105-1	Extractor Nipple Gasket — Inner	1
9	176-076-4	Extractor Nipple Seal Assembly — Syphon	1
9	176-077-4	Extractor Nipple Seal Assembly Air Eliminator	1
10	065-073-1	1/4" Galvanized Syphon Pipe (obtain locally or specify length)	1
11	013-147-1	1-1/4" Conduit Nipple (obtain locally or specify length)	1
N/S	164-045-4	Packer Assembly Air Eliminator	1
12	164-046-4	Packer Assembly with Syphon	1
13	058-029-1	Syphon Nozzle	1
N/S	066-163-3	Syphon Plug	1
14	072-110-1	O-ring — Syphon Plug & Nozzle	1
15	008-167-3	Syphon Injector Body	1
16	151-011-5	Discharge Manifold	1
17	031-108-1	Flange Gasket	1
18	065-786-3	Syphon Tube (specify length)	1

Item	Part No.	Description	No. Req'd.
19	065-784-3	3" Column Pipe (specify length)	1
N/S	882-xxx-x	Tank Riser Pipe (specify length)	1
20	065-785-3	3/4" Conduit Pipe (specify length)	1
21	208-271-5	Expansion Relief Valve	1
22	072-107-1	O-ring — Check Valve Seat	1
23	076-085-3	Check Valve Seat	1
24	079-161-1	Check Valve Spring	1
25	111-065-4	Cap & Stem Assembly for Check Valve	1
26	138-049-5	Disc & Holder Assembly for Check Valve	1
27	026-627-1	Pan Head Cap Brass Screw — 1/4-20 x 1/2	2
28	072-108-1	O-ring — Packer Assembly	3
29	026-414-1	Hex Head Cap Screw — 3/8-16 x 5/8	4
30	072-104-1	O-ring — Conduit Seal	2
31	072-129-3	Packer Locking Ring	1
32	060-057-1	Packing Nut — Packer	1
33	026-219-1	Square Head Cap Screw — 3/8-16 x 3/4	2
34	882-xxx-x	Extractor Nipple — (specify length) (includes 1 gasket 031-106)	1
35	066-164-3	Top Plate	1
36	031-107-1	Bolt Gasket	4
37	026-198-1	Hex Head Cap Screw — 3/4-10 x 1 3/4	4
N/S	144-191-5	Syphon Conversion Kit	1
N/S	064-025-3	Packer Casting Only	1

REPAIR PARTS LIST – BIG-FLO® SUBMERSIBLE PUMPS

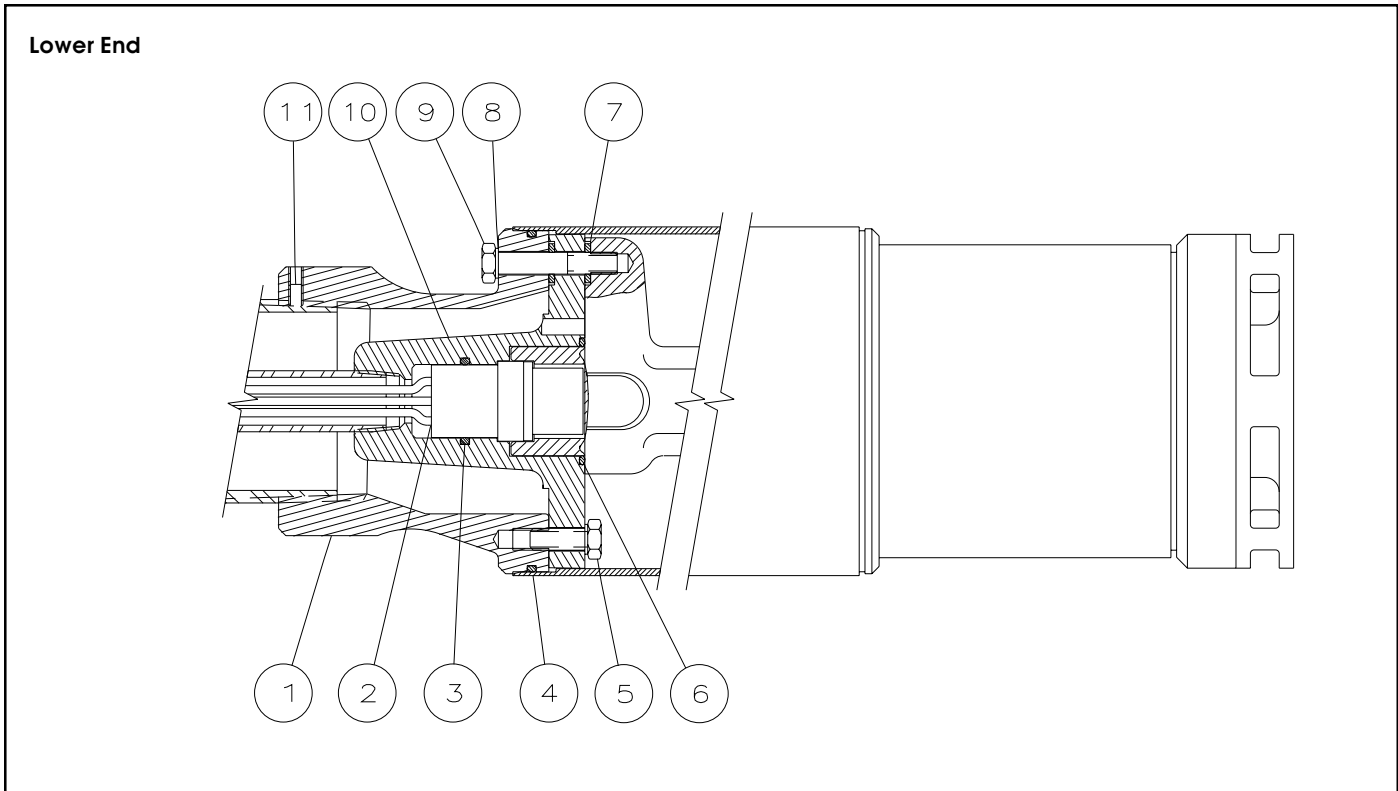

Item	Part No.	Description	Number Required						
			P200R1-2MB	P200R4-2MB	P300R4-2HB	P300R17-3HB	P500R4-2K	P500R6-2K	P500R17-3K
1	036-043-3	Head — Motor Discharge	1	1	1	1	1	1	1
2	113-540-1	Pigtail Connector — 3 Wire	1	1	1	1	1	—	1
2	113-541-1	Pigtail Connector — 5 Wire	—	—	—	—	—	1	—
3	072-622-1	Pigtail O-ring	1	1	1	1	1	1	1
4	072-109-1	Motor Shell O-ring	1	1	1	1	1	1	1
5	026-179-1	Screw — 3/8-16 x 1 Hex	1	1	1	1	1	1	1
6	072-623-1	Receptacle Housing O-ring	1	1	1	1	1	1	1
7	031-328-1	Gasket Bolt	8	8	8	8	8	8	8
8	026-110-1	Lockwasher 3/8" Spring	4	4	4	4	4	4	4
9	026-184-3	Screw — 3/8-16 x 2 1/4 Hex — Gr. 5	4	4	4	4	4	4	4
10	038-214-3	Housing Pigtail	1	1	1	1	1	1	1
11	026-448-1	Set Screw Fastener — 1/4"	2	2	2	2	2	2	2

Only the parts listed above are available for repairs of the lower end of the pump. If any other parts need replacing, order Red Jacket pump-motor assemblies. See back cover for ordering numbers.

MOTOR CONTROL BOX FOR CP200R1-2MB, 2 HP PUMP MODEL CBC-CP200R1

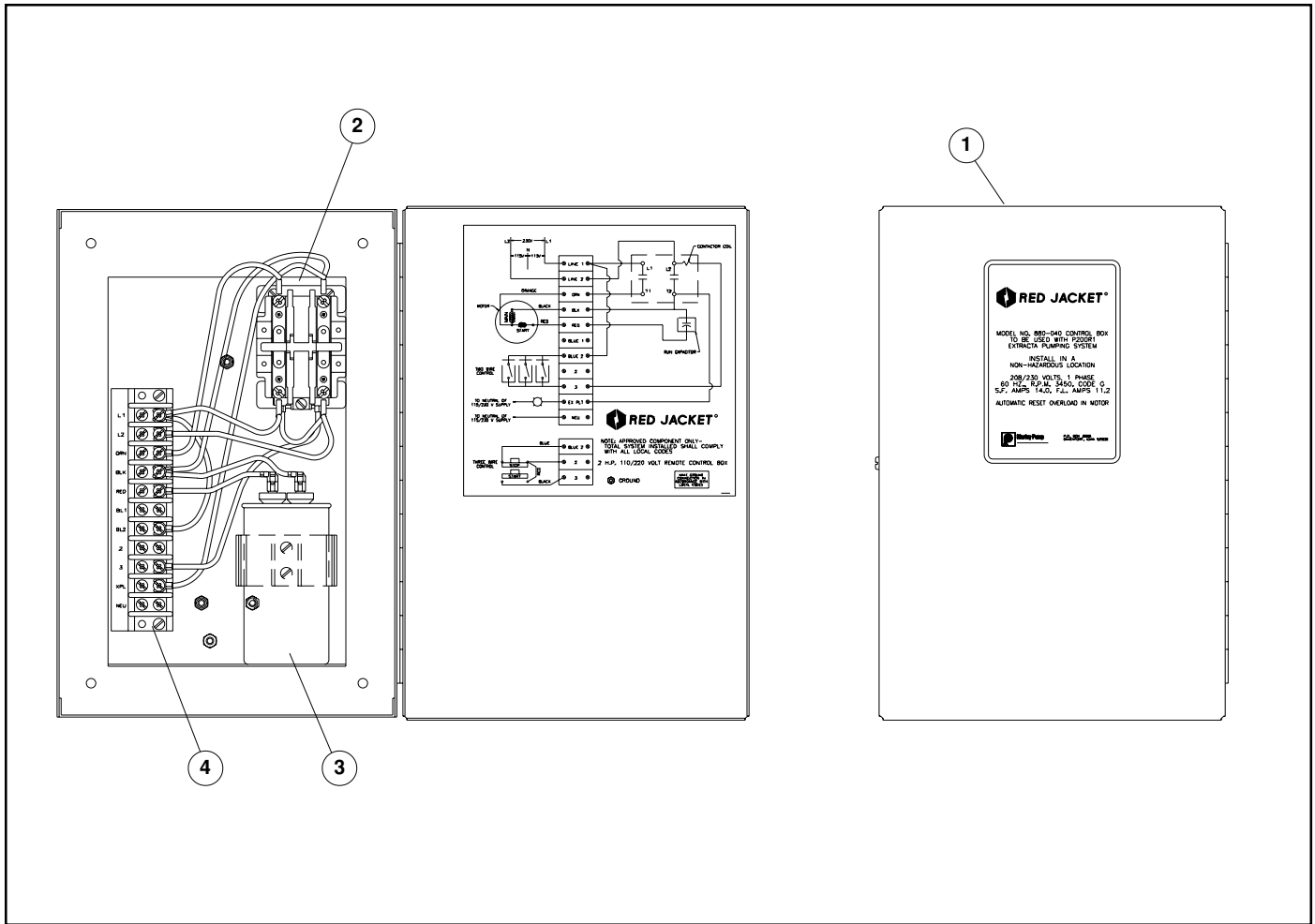

Key No.	Part No.	Description	No. Req'd.
1	880-040-5	P200R1 Complete General Purpose Control Box	1
2	014-724-1	Contactor	1
3	012-490-1	Run Capacitor	1
4	008-580-1	Terminal Block	1
N/S	880-039-5	Retrofit Kit - (Includes 2,3,4 and back panel)	1

MAGNETIC CONTACTOR FOR 2, 3 & 5 HP 3 PHASE PUMPS
MODELS P200R4-2MB, P300R4-2HB, P500R4-2K



DIMENSIONS: 8-5/8" (219 mm) Height — 5-11/16" (145 mm) Width — 4-1/8" (105 mm) Depth

HP	Volts	Phase	Part Number Magnetic Contactor and Enclosure
2	208-240	3	279-328-5
3	208-240	3	279-328-5
5	208-240	3	279-328-5
3	380-415	3	279-329-5
5	380-415	3	279-329-5

CAUTION

Three phase model Big Flo pumps require the use of a magnetic contactor. (Except for the 575 volt three phase Big Flo pump which requires a magnetic starter.)

**MAGNETIC STARTER FOR 575 VOLT, 5 HP, 3 PHASE PUMP
MODEL P500R6-2K**

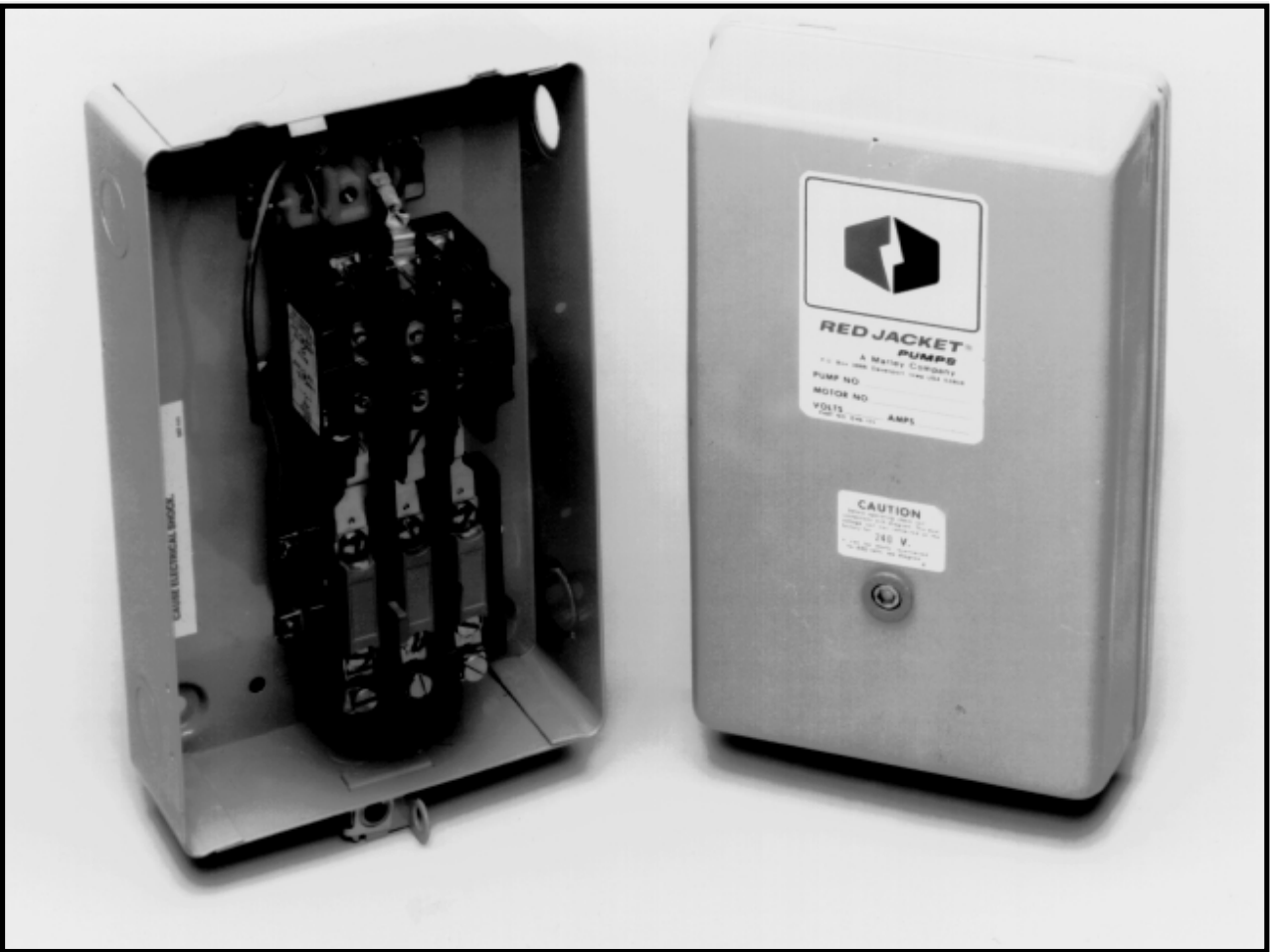

DIMENSIONS: 10-1/2" (267 mm) Height — 6-1/4" (159 mm) Width — 4-1/2" (114 mm) Depth

NOTICE

The only parts that are available for the Magnetic Starter from Red Jacket are the Overload Heaters. (See chart below).

HP	VOLTS	Phase	Magnetic Starter	Coil	Overload Heaters (3 Required)	
					Heater No.	Part No.
5	575	3	279-327-5	115/230	K49	036-073-1
5	575	3	279-230-5	575	K49	036-073-1

CAUTION

Only the 575 volt three phase model Big Flo pump require the use of a magnetic starter.

**RED JACKET REPLACEMENT PUMP MOTORS
BIG-FLO® SUBMERSIBLE PUMPS**

Ordering Number	Model Number	HP	Length in. (mm)	Weight lbs. (kg)	Volts	Phase
UMP						
887-001-5	UMP-P200R1-2MB	2	29.38 (746 mm)	115 (52)	208-240	1
887-002-5	UMP-P200R4-2MB	2	27.88 (708 mm)	108 (49)	208-240	3
887-003-5	UMP-P300R4-2HB	3	31.49 (800 mm)	115 (52)	208-240	3
887-006-5	UMP-P500R4-2K	5	41.22 (1047 mm)	162 (74)	208-240	3
887-004-5	UMP-P300R17-3HB	3	34.45 (875 mm)	120 (55)	380-415	3
887-008-5	UMP-P500R17-3K	5	45.85 (1165 mm)	167 (76)	380-415	3
887-007-5	UMP-P500R6-2K	5	41.22 (1047 mm)	162 (74)	575	3
UMP WITH FLOATING SUCTION ADAPTER						
887-533-5	UMP-200R1-2MB W/FSA	2	29.98 (761 mm)	115 (52)	208-240	1
887-534-5	UMP-P200R4-2MB W/FSA	2	28.48 (723 mm)	108 (49)	208-240	3
887-539-5	UMP-P300R4-2HB W/FSA	3	32.09 (815 mm)	115 (52)	208-240	3
887-543-5	UMP-P500R4-2K W/FSA	5	41.82 (1062 mm)	162 (74)	208-240	3
887-540-5	UMP-P300R17-3HB W/FSA	3	35.05 (890 mm)	120 (55)	380-415	3
887-545-5	UMP-P500R17-3K W/FSA	5	46.45 (1180 mm)	167 (76)	380-415	3
887-544-5	UMP-P500R6-2K W/FSA	5	41.82 (1062 mm)	162 (74)	575	3
UMP WITH DISCHARGE HEAD						
887-516-5	UMP-P200R1-2MB W/DH	2	32.04 (814 mm)	130 (59)	208-240	1
887-517-5	UMP-P200R4-2MB W/DH	2	30.54 (776 mm)	123 (56)	208-240	3
887-522-5	UMP-P300R4-2HB W/DH	3	34.15 (867 mm)	130 (59)	208-240	3
887-511-5	UMP-P500R4-2K W/DH	5	43.88 (1115 mm)	177 (80)	208-240	3
887-523-1	UMP-P300R17-3HB W/DH	3	37.11 (943 mm)	135 (61)	380-415	3
887-513-5	UMP-P500R17-3K W/DH	5	48.51 (1282 mm)	182 (83)	380-415	3
887-512-5	UMP-P500R6-2K W/DH	5	43.89 (1115 mm)	177 (80)	575	3

PROCEDURE FOR REMOVAL OF PLUG-IN TYPE PUMP-MOTOR ASSEMBLY

DANGER Always Disconnect and lock or tag out the power before starting to service the pump.

1. Remove Red Jacket Pump from product storage tank.
2. Lay pump in horizontal position.
3. Block pump so that pump end is two inches above surface.
4. Remove four 3/8" cap screws.
5. Using hands, grip pump at extreme bottom and rock in arch not exceeding 1/4" path. This allows pump to free past dowel pin.
6. Slide pump away from column. Watch to be sure electrical (Bayonet type) plug-in separates.
7. If plug-in does not disconnect, continue sliding pump motor until plug-in is exposed for hand separating.
8. Assemble new pump motor in reverse order. Check plug-in connection and dowel pin location.
9. Use new pump seal "O" ring which is supplied with pump motor assembly.
10. Lubricate pump "O" ring with silicone lubricant.
11. When drawing up 3/8" cap screws, be sure to draw evenly. Torque to 29 ft.-lbs.

Accu-Flo  **www.accuflo.com**
Meter Service Ltd. **1-800-921-ACCU**

 **REDJACKET**[®]
by  **VEEDER-ROOT**