



**RED SEAL  
MEASUREMENT**

**Accu-Flo**  
Meter Service Ltd.

[www.accuflo.com](http://www.accuflo.com)  
1-800-921-ACCU



## Operating and Maintenance For LP Gas Meters

M282  
Rev. B  
P.D. Oscillating Piston Flowmeters:  
1 1/4" - 4D LP Gas  
1 1/2" - 4D LP Gas



## TABLE OF CONTENTS

|                                     |    |
|-------------------------------------|----|
| General Information .....           | 1  |
| Installation .....                  | 1  |
| Operation .....                     | 3  |
| Calibration .....                   | 4  |
| Maintenance .....                   | 5  |
| Registration .....                  | 6  |
| Measuring Chamber Maintenance ..... | 7  |
| General Maintenance .....           | 8  |
| Troubleshooting .....               | 12 |

# 1¼" and 1½" COMPACT FLOWMETERS TYPE 4D STYLE N FOR LP GAS INCLUDING PROPANE TEMPERATURE COMPENSATOR

## GENERAL INFORMATION

This manual covers the installation and maintenance of the 1¼" and the 1½" Type 4D Style N LP Gas Compact Flowmeters (figures 1 and 2), each of which includes a Strainer, Vapor Release and Differential Valve. These flowmeters can be provided either with or without Automatic Temperature Compensation. (See figure 2).

The Strainer, housed in the Vapor Release at the intake of the flowmeter, is of a fine mesh construction.

The Vapor Release, which vents entrapped vapor, has a hydraulically assisted main valve with a float operated pilot valve. When vapor collects in the Vapor Release, the vent valve opens, venting vapor to the supply tank and establishing pump pressure to close the Differential Valve. The Vapor Release includes a bypass valve to relieve excessive pressure to the supply tank. This bypass valve includes a venting feature for ease in bleeding off product for maintenance purposes.

The Differential Valve is diaphragm actuated and opens when at least 15 psi pump pressure is established at the inlet of the flowmeter. This valve serves three functions to assure system measurement accuracy by requiring: (1) pump operation for delivery, (2) adequate back pressure to prevent product vaporization during measurement, and (3) blockage of flow when the Vapor Release valve opens.

The temperature compensator, by sensing product temperature, controls the readout drive ratio to provide a registration compensated to 60°F.

## INSTALLATION

### Before installing the flowmeter

1. Plan the installation for maximum rate of delivery, sizing the supply tank outlet, piping and valve for free gravity flow to the pump suction. To accomplish this, locate the pump as close as possible to the supply tank and use short inlet connections with few restrictions. Keep the number of elbows to a minimum, and use large radius elbows, wherever possible. To further reduce the likelihood of causing vapor in the pump suction line, install a pump bypass valve in a return line to the supply tank as shown in the installation drawing. (See figure 3.)

2. Locate the flowmeter at any convenient place in the pump discharge line. If the flowmeter is to be operated under extreme environmental conditions (dirt, water, physical damage, etc.), an enclosure should be provided. Allow sufficient clearances for removal of the register, strainer and vapor release as shown in Figure 15. **Do not install a bypass around the flowmeter;** the valve in such a line might eventually leak, work open, or be left open causing improper measurement.

To conform with Weights and Measures requirements, install the flowmeter (right or left-hand assembly) so that the nameplate is visible.

All piping on the inlet side of the flowmeter should be thoroughly cleaned out. Flush out all lines thoroughly before installing the flowmeter.

While the installation is still new, the strainer should be cleaned frequently. After the system has been thoroughly flushed of foreign material, only periodic cleaning is recommended.

***The majority of service calls on new installations will be eliminated if these directions are followed.***

## GENERAL INFORMATION

## INSTALLATION

Before Installing the Flowmeter



**FIGURE 1**  
**1 1/4" TYPE 4D COMPACT FLOWMETER**  
**WITH AUTOMATIC TEMPERATURE**  
**COMPENSATOR**



**FIGURE 2**  
**1 1/2" TYPE 4D COMPACT**  
**FLOWMETER WITH AUTOMATIC**  
**TEMPERATURE COMPENSATOR**

Secure the connecting pipe to prevent strain on the flowmeter. Use pipe compound sparingly or suitable piping tape on male threads only.

Provide the installation with means for pressure relief as outlined in the National Fire Protection Association Pamphlet 58.

The vent line from the flowmeter's vapor vent to the vapor space of the supply tank should be 3/8" OD tubing or equivalent pipe size. The vent line check valve functions as a shut off valve when disconnected and permits removal of the strainer for cleaning or when other service is performed on the flowmeter. The Vapor Release vent line must be returned to the vapor space of the supply tank and normally should not be made a common connection with other vapor lines or pump bypass lines. When properly installed, this line must permit free flow in either direction. If valve in vent line is closed, the flowmeter will not function. These instructions must be followed in order to maintain proper function of the differential valve.

**NOTE:** A vapor equalizing line should not be used from the supply tank to the vessel being filled, as such a connection would cause confusion as to the amount delivered as a result of possible passage of vapor in either direction.

**When Installing**

**Vent Line**

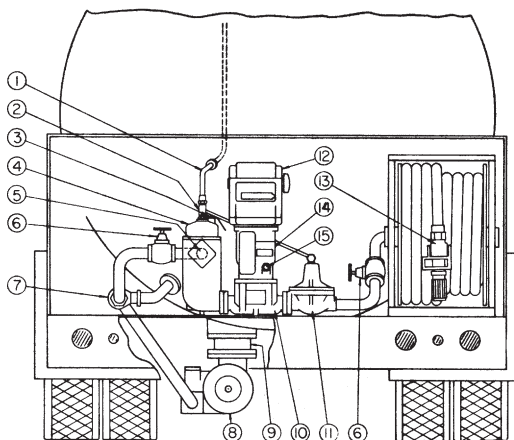

1. Vapor Vent Line
2. Vent Line Check Valve
3. Pressure Bypass
4. Vapor Release
5. Inlet Check Valve and Strainer
6. Manual Valve
7. External Pump Bypass Valve
8. Pump
9. Internal Control Valve
10. Flowmeter
11. Differential Valve
12. Flowmeter Register
13. Hose Valve
14. Automatic Temperature Compensator
15. Thermometer Well

**FIGURE 3**  
**FLOWMETER INSTALLATION**

## OPERATION

Pressurize the system slowly by allowing vapor flow through the vent line. Check for system leaks. Then pass sufficient liquid through the system to clear the lines of air and vapor.

After starting pump, slowly open outlet valve downstream of the flowmeter. Check the rate of flow after the system is filled; it should not exceed rated maximum flow.

Adjust the external pump bypass to deliver the maximum practical rate of flow for the least amount of pump pressure.

**NOTE: The pump relief valve (typically built into the pump assembly) should relieve at a pressure above which the external bypass has been set.**

Maximum working pressure on the system must not exceed 350 psi. Avoid the use of small diameter hose or pipe and resultant need for excessive pressures to achieve the desired flow rates; these may result in leakage, undue wear on pump and unsafe operation.

All flowmeters are carefully calibrated and tested after assembly, however system calibration is necessary after installation.

While the installation is still new, clean the strainer frequently. After the system has been in service, only periodic cleaning is necessary.

## To Operate the Flowmeter

1. Reset register to zero by turning reset knob to the rear stop. On Printer models, first insert ticket. (See figure 4.)
2. Start pump.
3. Open hose valve and make delivery.
4. After completion of delivery on Printer models, stamp final reading on ticket by turning reset knob to the front stop and remove ticket.



**FIGURE 4  
PRINTER REGISTER**

Cumulative totalizer is visible through the mask at the upper right corner of register.

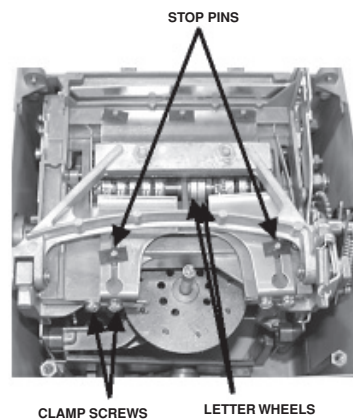

**FIGURE 5  
PRINT UNIT ADJUSTMENTS**

## Printer Models

To insert a ticket be sure that the reset knob is turned forward to a stop. Then depress the dust bar above the ticket slot (see figure 4), and insert ticket either “face down, bottom end first” or “face up, top end first” as noted on instruction plate. Turn operating knob backward to stop. This resets the visible wheels to zero, locks the ticket in place, and prints the initial reading on the ticket. (Ticket now cannot be removed without tearing it.)

## OPERATION

### To Operate the Flowmeter

**Totalizer**

**To Insert and  
Remove Tickets**

Upon completion of delivery, turn the reset knob forward to stop. This operation prints the final reading and releases the ticket.

## To Adjust Ticket Guides

Printer registers are shipped from factory with the ticket guides properly adjusted. If it is necessary to reposition ticket, proceed as follows:

1. Remove top cover.
2. Insert ticket into printer. Loosen screws on rear of ticket guides (see figure 5). Move guides to right or left as required. Tighten screws. The ticket must slide freely between the guides. If ticket binds at forward end of guide, remove guide and rebend tail.
3. To raise or lower printing, push the two stop pins to the front or rear with end of a screwdriver.
4. Replace top cover and reseal.

## To Change "Letter Wheel" Setting

1. With top cover removed the "letter" wheels are visible. (See figure 5).
2. Using screwdriver or similar tool, turn wheels until desired letters are in position to print. The letters appearing at top are in position to print.

## CALIBRATION

Test the flowmeter by using a volumetric prover large enough to permit the flowmeter to operate for at least one minute at maximum flow rate. Slip tube and rotary gauge readings are not sufficiently accurate for proving flowmeters. A detailed description of LP Gas test procedure may be found in the NCWM Course 305 "Liquefied Petroleum Gas Liquid — Measuring Devices." Specifications and Tolerances are contained in NBS Handbook H-44.

A thermometer well is provided for taking temperature readings while calibrating. It is located in the compensator on compensated flowmeters. On uncompensated flowmeters it will be found in the strainer cover. It is covered by a snap plug to keep dirt from entering the well. The well should be filled with permanent type antifreeze, if available, or with a light oil when temperature readings are to be obtained.

If a gravimetric test is used, the conversion to gallons must be on the basis of: (1) specific gravity determined at the time of test (not an assumed value), (2) the temperature of the product as it passed through the flowmeter.

Erratic registration may be an indication of vapor or dirt in the measuring chamber. It cannot be corrected by recalibration. Clean the strainer and, if necessary, the flowmeter as directed under MAINTENANCE. For proper operation, the installation must be as shown in figure 3.

When the flowmeter registers consistently either more or less than is delivered, the calibration may be corrected in the following manner.

## On Uncompensated Flowmeters

Test the flowmeter to determine any error in registration. If there is an error less than 0.3%, proceed as follows:

1. Remove the register top cover.
2. Lift and turn change gear shifter (see figure 6) in the direction indicated on the top of the shifter.
3. There is a series of holes in the plate into which the guide pin enters at different settings. Altering the setting by one hole changes the calibration approximately 34 cubic inches in 100 gallons.

For example: Suppose the flowmeter consistently delivers 68 cubic inches too much when it registers 100 gallons. After removing the cover plate move the gear shifter 2 spaces to the right (from position E to position C) to decrease the delivery about 68 cubic inches in 100 gallons.

After changing the calibration always replace top cover, making sure the housing on the sides and back fits into the groove in the bottom edge of cover. Run a small amount of liquid through the flowmeter before testing. In order to prevent tampering, always reseal after calibration is completed.

## CALIBRATION

### Erratic Registration

### Consistent Over- or Under-Registration

If there is an error greater than 0.3% (approx. 68 cu. in. in 100 gals.), proceed as follows:

1. Remove the register. (Refer to REGISTER MAINTENANCE.)
2. Looking into the bottom of the register, determine the number of teeth on the "R" and "S" change gears. (See figure 7.)

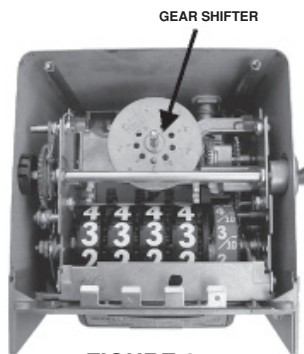

**FIGURE 6**  
**GEAR SHIFTER ADJUSTMENTS**

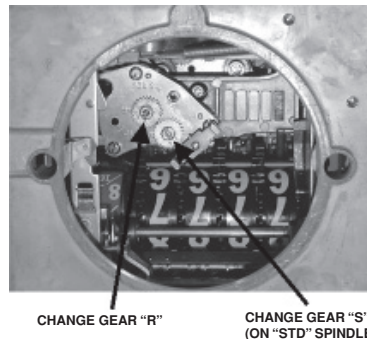

**FIGURE 7**  
**CHANGE GEAR ARRANGEMENT**

3. Refer to CHANGE GEAR CHART and select the proper gears.
4. Install new gears. Be sure to put change gear "R" on the "R" spindle and change gear "S" on the "S" spindle.
5. Replace register and tighten two clamp screws.

## On Compensated Flowmeters

1. Remove the two seal screws and cover from the temperature compensator. (See figure 8.) (Do not remove sealing wax at top of lever arm.)
2. Move anchor pin from "Compensated Anchor" to "Uncompensated Anchor." (Flowmeter readings will now be uncompensated.) (See figure 8.)
3. Perform same LP Gas flowmeter test procedures as outlined for uncompensated meters.
4. If necessary to change flowmeter calibration, refer to ON UNCOMPENSATED FLOWMETERS.
5. Move anchor pin to "Compensated Anchor," and operate flowmeter for at least 50 gallons before proceeding with calibration tests. (Flowmeter readings will now be temperature compensated.)
6. Perform same flowmeter test procedure used for uncompensated flowmeter. Temperature readings must be taken **at the prover only**. (Temperature at flowmeter is assumed to be 60°F).
7. If necessary, to adjust compensated registration, turn calibration dial located at the lower end of the Lever Arm (to turn adjustment, use wrench on hex hub of dial). Turn clockwise "To Give More" or counterclockwise "To Give Less." Each dial graduation will change compensated delivery approximately 0.15%; that is, 34 cubic inches per 100 gallons.

## MAINTENANCE

For sustained accuracy of Actaris Neptune Flowmeters, little maintenance is required other than to see that the proper conditions of operation are preserved. Once the flowmeter has been installed correctly, these conditions consist merely in guarding against foreign matter, such as vapor, sediment or water entering the measuring chamber. However, should any malfunction develop, do not dismantle the flowmeter until the cause of the trouble has first been determined. Refer to suggestions in "TROUBLESHOOTING."

The liquid passing through the measuring chamber must be free of grit and other forms of sediment to prevent unnecessary friction and to eliminate scoring of the piston and chamber walls. Evidence of trouble from this source will be found in under-registration of the flowmeter. Periodic cleaning and inspection of the flowmeter strainer will help to insure maximum flow rate and to prevent possible damage of the flowmeter if clogged strainer ruptures.

## MAINTENANCE

### General Maintenance

### Sediment

Being an instrument that measures by volume, a flowmeter will record the passage of vapor as well as the liquid being measured, resulting in over-registration. This will not occur with proper Vapor Release and Differential Valve function and installation.

**SAMPLE CHANGE GEAR CHART**

| REG. GEAR "R"          | STUFF. BOX GEAR "S" | CHANGE |                       |
|------------------------|---------------------|--------|-----------------------|
|                        |                     | %      | CU. IN. in 100 US GAL |
| 1 1/2" METERS          |                     |        |                       |
| 21                     | 22                  | .21    | 48                    |
| 22                     | 23                  | .19    | 44                    |
| 23                     | 24                  | .18    | 42                    |
| 24                     | 25                  | .16    | 38                    |
| 25                     | 26                  | .15    | 34                    |
| 26                     | 27                  | .15    | 34                    |
| 27                     | 28                  | .12    | 28                    |
| 28                     | 29                  | .11    | 26                    |
| 29                     | 30                  | .12    | 28                    |
| 30                     | 31                  | .20    | 46                    |
| 32                     | 33                  | .26    | 60                    |
| 35                     | 36                  |        |                       |
| 1 1/4" x 1 1/4" METERS |                     |        |                       |
| 23                     | 25                  | .33    | 46                    |
| 24                     | 26                  | .31    | 72                    |
| 25                     | 27                  | .29    | 68                    |
| 26                     | 28                  | .27    | 62                    |
| 27                     | 29                  | .24    | 56                    |
| 28                     | 30                  | .23    | 54                    |
| 29                     | 31                  | .21    | 48                    |
| 30                     | 32                  | .20    | 46                    |
| 31                     | 33                  | .18    | 42                    |
| 32                     | 34                  | .18    | 42                    |
| 33                     | 35                  | .18    | 42                    |
| 34                     | 36                  | .17    | 40                    |

↑ TO DELIVER LESS (INCREASE REGISTRATION)  
↓ TO DELIVER MORE (DECREASE REGISTRATION)

**REGISTER "CHANGE GEARS" FOR 1 1/2" FLOWMETERS (U.S. GALLONS)**

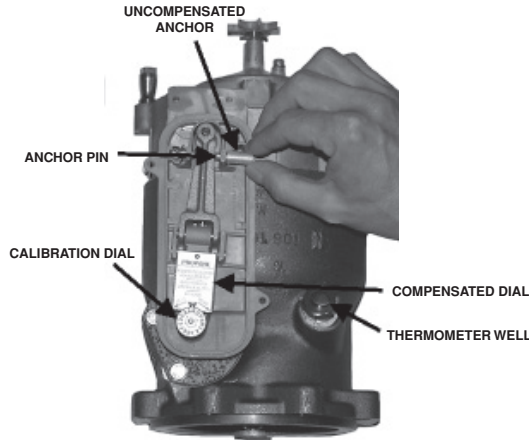

**FIGURE 8 REMOVING ANCHOR PIN FOR CALIBRATION**

Incidental water will cause no damage to the flowmeter. Trouble from this source may be expected only when water is allowed to remain in the flowmeter.

**REGISTRATION**

Erratic registration is usually caused by vaporization of the product, faulty differential valve or vapor release function or installation (over-registration), or by dirt or pipe scale in the measuring chamber (under-registration). Clean the flowmeter, if necessary, as directed in MEASURING CHAMBER MAINTENANCE. If flowmeter continues to creep when outlet valve is closed, check differential valve diaphragm.

When the flowmeter consistently registers either more or less than is delivered and no other cause in system function can be determined, calibration of the metering system is recommended.

Before placing in storage the flowmeter assembly must be flushed with a light lubricating oil of good quality to prevent corrosion from condensation.

Register parts are such that only minor field repairs are advisable. When a register is in need of repair or service other than that for which instruction is given here, it should be returned to an authorized Actaris Neptune distributor.

Loosen the two clamp screws on lower front of the register. Lift the register from the flowmeter.

When one register is removed and another substituted: (1) Check the number of teeth on the "change gears" (See figure 7). They must be the same as the gears on the old register and on the same respective spindles. The number of teeth is stamped on each gear. To remove these gears, close the split end of the spindle slightly with a pair of pliers and pull off the gear. After putting on a gear, spread the end of the spindle slightly. (2) Make sure that the position of the "Gear Shifter" is the same on the new register as on the old one.

Register masks are made of plastic and require special treatment. Instructions for cleaning are given below:

A water solution of nonabrasive soap is recommended for washing grease, oil, or dirt from the mask. It is then cleansed by rubbing gently with a soft cloth, in a manner similar to cleaning window glass, rinsing the plastic in clean water, and finally drying.

Scouring cleanser and similar material must not be used for cleaning masks, since they contain abrasives that scratch the surface.

Vapor

Water

**REGISTRATION  
Erratic Registration**

**Consistent Over- or Under-Registration**

**Storage**

**Register Maintenance**

**To Remove Register From Flowmeter or Temperature Compensator**

**To Clean Register Masks**



The use of solvents, such as acetone, ethyl acetate, benzene, and ethylene dichloride, to brighten the surface is never recommended since these substances soften the surface of the plastic.

## MEASURING CHAMBER MAINTENANCE

### CAUTION

Before opening any part of the flowmeter, close valve between supply tank and flowmeter. Disconnect coupling in vent line at vapor release cover. **Perform the following outdoors, away from buildings or sources of ignition:**

Open valve slowly at end of delivery hose or other outlet piping. After pressure is dissipated, unscrew Vent Valve (hex. nut) slowly (maximum 3 turns) on top of Vapor Release to depressurize product in flowmeter.

For this operation, no special tools are required. No trouble need be expected if these few simple but important directions are followed. Do not open the flowmeter until you have checked over all other possible causes of erratic registration. Reference "TROUBLESHOOTING."

1. Prepare a clean surface on which to place the parts as they are removed. (The parts are machined to close tolerances and should be handled with care.) Also check that a replacement gasket is on hand before opening the flowmeter.
2. Loosen the two clamp screws on the lower front of the register. Lift the register from the flowmeter.
3. Remove the flowmeter cover or Compensator, taking care not to damage the gasket.
4. Remove the measuring chamber from the flowmeter casing.
5. Remove the upper cylinder head by inserting a screwdriver in one of the slots provided and pry it off. Be careful not to scratch or nick any part of the chamber.
6. Lift out the piston by its spindle. If care is taken to draw it straight, it should come out easily. Do not force it.
7. Remove the control roller from the lower cylinder head. If the diaphragm or seal pin require replacement, they may be removed by pulling upward, using pliers if necessary.

The parts may be most easily cleaned of scale, embedded chips, heavy corrosion and other foreign matter using gasoline and a coarse, stiff-bristle (not wire) brush. Do not use abrasives, such as emery cloth or sandpaper. When the piston is badly corroded, replace the whole chamber.

The sliding surfaces between the chamber and piston take on a burnished finish and wear little, if any. The parts of the measuring chamber which may show wear after long periods of service are the diaphragm and the control roller. These parts will not require replacement until the accuracy of the flowmeter begins to fall at low flow rates. To change these parts merely substitute new parts for the old when the flowmeter is disassembled for cleaning.

Before assembling the flowmeter, make sure all parts are clean. If possible, flush out the flowmeter body. Assemble the parts carefully, they should slide together easily without hammering or forcing. It is essential that all contact surfaces between the upper and lower cylinder heads and the cylinder, or between the measuring chamber and its seat in the casing, be clean and free from nicks.

1. Assemble the diaphragm and seal pin in the chamber, if these parts were replaced.
2. Place the control roller on its pin; make certain it freely rotates.

## MEASURING CHAMBER MAINTENANCE

### To Remove and Disassemble

### To Clean the Measuring Chamber

### To Reassemble the Chamber in the Flowmeter

3. Replace the piston and oscillate it carefully by hand. It should move easily without binding. (See figure 9.) If it sticks, remove it and locate the cause. Do not file down the roller as this will destroy the accuracy of the flowmeter.
4. Replace the upper cylinder head, and again oscillate the piston to make sure that it is free.
5. Before installing the measuring chamber in the casing, make sure that the seat is clean and free of nicks. Install the chamber, making sure that the dowel pin in the main casing enters the slot in the bottom cylinder head properly and allows the chamber to rest squarely on the seat. The top of the chamber should be flush with the gasket seat.

## GENERAL MAINTENANCE

### Vapor Release & Strainer Maintenance

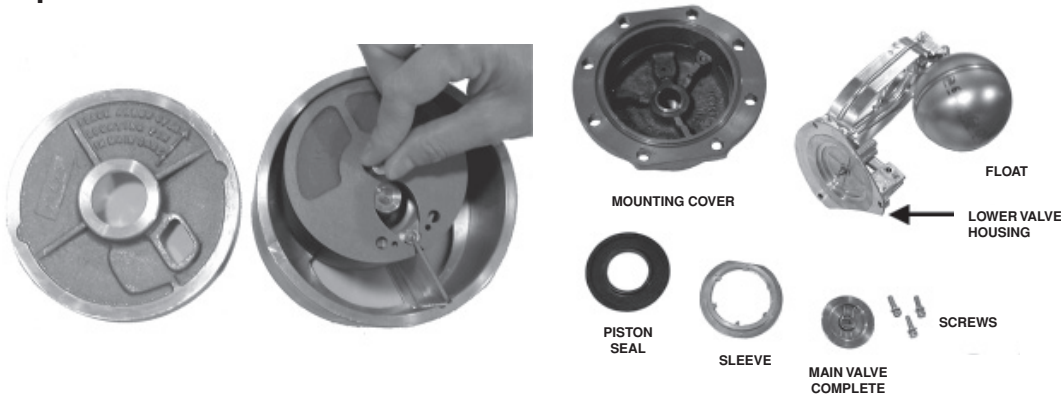

**FIGURE 9**  
**CHECKING PISTON FREEDOM**

**FIGURE 10**  
**VAPOR RELEASE COMPONENTS**

#### CAUTION

Before opening any part of the flowmeter, close valve between supply tank and flowmeter. Disconnect coupling in vent line at vapor release cover. **Perform the following outdoors, away from buildings or sources of ignition:**

Open valve slowly at end of delivery hose or other outlet piping. After pressure is dissipated, unscrew Vent Valve (hex. nut) slowly (maximum 3 turns) on top of Vapor Release to depressurize product in flowmeter.

Remove the strainer cover and pull out the screen. Blow the dirt off screen with compressed air and rinse in gasoline.

Trouble with this unit may arise from: (1) Collapsed float allowing vent to remain open; (2) dirty or worn valve disk; or (3) binds in float linkage.

1. Uncouple the vent connection. (See Caution.)
2. Remove the cap screws on the Vapor Release cover, and lift out the mechanism.
3. If the float is damaged, remove by taking out the hinge pin and replace with a new one.
4. If the valve is leaky,
  - a. Remove the vapor release unit from the underside of the cover (by unscrewing three screws).
  - b. Take out the sleeve. (See figure 10.)
  - c. Move the float in the direction of the valve housing as far as possible and remove valve disk assembly.
  - d. The valve disk assembly should be taken apart to inspect for dirt or defective pilot valve seat. Replace valve, if disk is defective.
  - e. When reassembling, make sure that the valve disk assembly moves freely in sleeve.

## GENERAL MAINTENANCE

### To Clean the Strainer

### Vapor Release Valve

### To Inspect

CAUTION

Before opening any part of the flowmeter, close valve between supply tank and flowmeter. Disconnect coupling in vent line at vapor release cover. **Perform the following outdoors, away from buildings or sources of ignition:**

Open valve slowly at end of delivery hose or other outlet piping. After pressure is dissipated, unscrew Vent Valve (hex. nut) slowly (maximum 3 turns) on top of Vapor Release to depressurize product in flowmeter.

## Differential Valve

### To Disassemble

Faulty operation of this unit may be caused by defective valve seat or torn diaphragm.

1. Remove connecting tube at the top of unit.
2. Remove 10 of the 12 cover bolts leaving 2 screws on opposite sides in place.
3. Slowly remove last 2 screws while holding cover down to oppose internal spring.
4. Disassemble diaphragm assembly as necessary to replace parts (see figure 12).

### To Reassemble

1. Assemble diaphragm assembly. First apply continuous bead of "Permatex Aviation Form-A-Gasket Part Number 3D" around center hole on both sides of diaphragm.
2. Insert spring and diaphragm assembly into cover.
3. Align bolt holes in diaphragm with those in cover using 2 screws on opposite sides, and engage threads of screws.
4. Mount cover assembly on valve body and assemble and tighten 12 screws evenly.
5. Install connecting tube to elbow fitting.

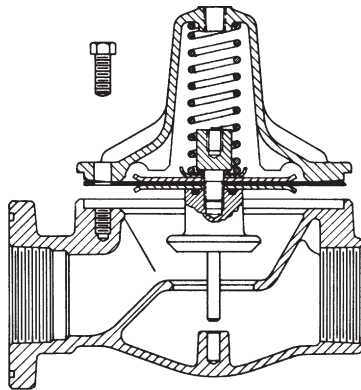

**FIGURE 11**  
**DIFFERENTIAL VALVE**



**FIGURE 12**  
**DIFFERENTIAL VALVE COMPONENTS**

## Temperature Compensator

The Compensator is designed to give long and dependable service when properly installed. The unit has been thoroughly performance tested prior to shipment, and in normal service requires no further lubrication.

Maintenance of the compensator should be limited to those operations outlined below. If it becomes apparent that the unit is in need of repair, the compensator should be returned to the nearest authorized Actaris Neptune distributor.

### To Remove Compensator

1. Remove the register.
2. Remove cover bolts at the base of the compensator and lift the unit off, taking care not to damage the gasket.

**To Disassemble**

**To Reassemble**

**To Repair  
Compensator**

**To Remove  
Compensator**

## To Replace Compensator

1. Mount the compensator with the cover toward the front of the flowmeter. Care should be exercised to set arm of compensator gear train so that it will not come down on top of the piston spindle.
2. Make sure that compensator is down on gasket before tightening bolts.
3. Tighten all bolts.

To assemble a compensator on uncompensated flowmeters, follow above steps after first removing main case cover and replacing gasket, if necessary. Reuse bolts taken from main case cover.

## To Remove Compensating Mechanism

1. Remove two seal screws and take off "Neptune" cover. (See figure 13.)
2. Withdraw anchor pin after removing cotter pin.
3. Remove three screws and take off lever arm plate.
4. Remove four screws around top edge of compensator and lift off upper housing.

## To Replace Thermostat

1. Perform Steps 1–3 found under "To Remove Compensating Mechanism."

### CAUTION

Before opening any part of the flowmeter, close valve between supply tank and flowmeter. Disconnect coupling in vent line at vapor release cover. **Perform the following outdoors, away from buildings or sources of ignition:**

Open valve slowly at end of delivery hose or other outlet piping. After pressure is dissipated, unscrew Vent Valve (hex. nut) slowly (maximum 3 turns) on top of Vapor Release to depressurize product in flowmeter.

2. Remove four screws and lift off thermostat cover.
3. Lift out thermostat being careful not to damage thermostat gasket.

## Gear Train Maintenance To Service Gear Train Shaft Seal Or To Replace Gear Train

### CAUTION

See CAUTION above.

Keep dirt out of flowmeter and avoid damage to gasket.

1. On all flowmeters remove the register. On meters with compensator, disassemble the compensator. On meters without compensator, remove the register and the meter cover.
2. Remove the star connection (1) using No. 8 Allen wrench (See figure 14.)
3. Unscrew the stuffing box nut (2).
4. Remove shaft seal (3). Inspect top of spindle to be sure it is free of nicks or burrs which might damage the new shaft seal when it is placed on spindle. Remove clamp nut (6); gear train assembly can be removed from underside of flowmeter cover or compensator.
5. Replace shaft seal with new part. Be sure expander (4), and spring (5) are in position before inserting new seal.
6. Assemble nut and tighten down all the way.

## To Replace Compensator

## To Remove Compensating Mechanism

## To Replace Thermostat

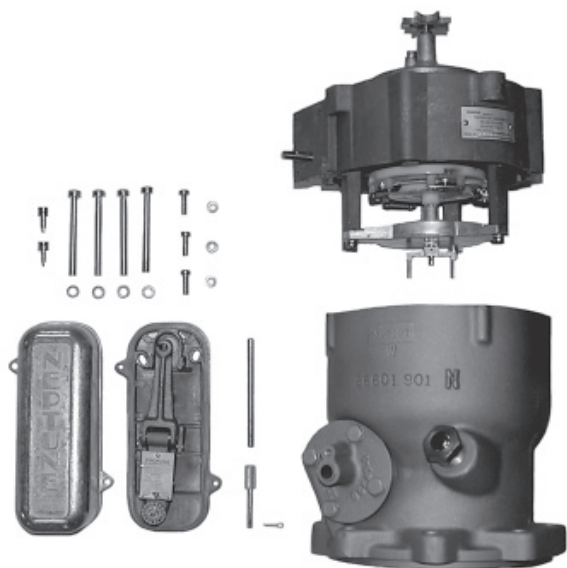

**FIGURE 13  
AUTOMATIC TEMPERATURE  
COMPENSATOR COMPONENTS**

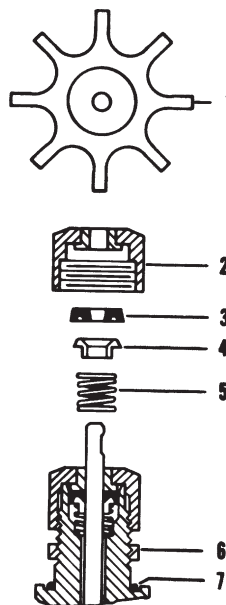

**FIGURE 14  
STUFFING BOX  
COMPONENTS**

**CAUTION**

Before opening any part of the flowmeter, close valve between supply tank and flowmeter. Disconnect coupling in vent line at vapor release cover. **Perform the following outdoors, away from buildings or sources of ignition:**

Open valve slowly at end of delivery hose or other outlet piping. After pressure is dissipated, unscrew Vent Valve (hex. nut) slowly (maximum 3 turns) on top of Vapor Release to depressurize product in flowmeter.

## TROUBLESHOOTING

## TROUBLESHOOTING

- 1. Register not working when liquid is flowing.**
  - a. Bypass around flowmeter not shut off.
  - b. Ice inside register.
  - c. Loose register or worn gear train.
  - d. Register in need of repair.
  - e. Sheared key on Change Gear caused by ice in register or mechanically tight mechanism.
- 2. Leakage at the stuffing box.**
  - a. Worn shaft seal or spindle.
- 3. Chronic leakage at the main case gaskets.**
  - a. Dirty or defective seat or excessive shock pressure.
  - b. Defective gasket or loose bolts.
- 4. Unsatisfactory flow rate or complete stoppage of flow.**
  - a. Obstruction in vapor vent line between differential pressure valve and vapor space in tank.
  - b. Pump too small or inefficient. (The pump must have sufficient capacity and efficiency to pump against higher heads than are normally found in gasoline or fuel oil installations. This is especially true when the delivery nears completion.)
  - c. Pump vapor bound due to improper installation of bypass relief valve or restriction in suction line.
  - d. Pump bypass stuck open or spring weak.
  - e. High loss of head. (This is caused by too many valves and elbows and the length, diameter and condition of the delivery hose.)
  - f. Pressure buildup in tank being filled. Condition becomes worse as delivery nears completion unless vapor return line (not recommended) is used or vapor space type filling is used.
  - g. Blocked strainer, or piston in flowmeter stuck. Clean strainer and/or measuring chamber.
  - h. Open valve in piping allowing liquid to circulate around pump.
  - i. Worn pump.
  - j. Vapor release valve fails to close.
  - k. Pressure build up on vent line.
- 5. Under registration — erratic.**
  - a. Dirt in the measuring chamber.
  - b. Badly worn control roller or diaphragm.
  - c. Main casing damaged.
  - d. Dirt under seat of measuring chamber (after cleaning).
- 6. Over registration — erratic.**
  - a. Diaphragm in differential pressure valve ruptured.
  - b. Vapor release valve remaining closed, allowing vapor to pass through meter.
- 7. Consistent over or under registration**
  - a. Flowmeter in need of calibration.
- 8. Printing not clear in cold weather.**
  - a. Ticket carbon not suitable for cold weather use.

**DIMENSIONAL DATA**

| DIMENSIONS |            |            |
|------------|------------|------------|
|            | <i>in.</i> | <i>mm.</i> |
| A          | 10.38      | 263.53     |
| B          | 5.88       | 149.23     |
| C          | 7.50       | 190.50     |
| D          | 22.63      | 574.68     |
| E          | 6.13       | 155.58     |
| F          | 9.38       | 238.13     |
| G          | 2.88       | 73.03      |
| H          | 0.63       | 15.88      |
| I          | 4.69       | 119.06     |
| J          | 0.75       | 19.05      |
| K          | 5.00       | 127.00     |
| L          | 17.81      | 452.44     |
| M          | 9.25       | 234.95     |
| N          | 1.94       | 49.21      |
| O          | 4.00       | 101.60     |
| P          | 5.31       | 134.94     |
| Q          | 1.31       | 33.34      |
| R          | 5.25       | 133.35     |
| S          | 4.25       | 107.95     |
| T          | 3.00       | 76.20      |
| U          | 6.75       | 171.45     |

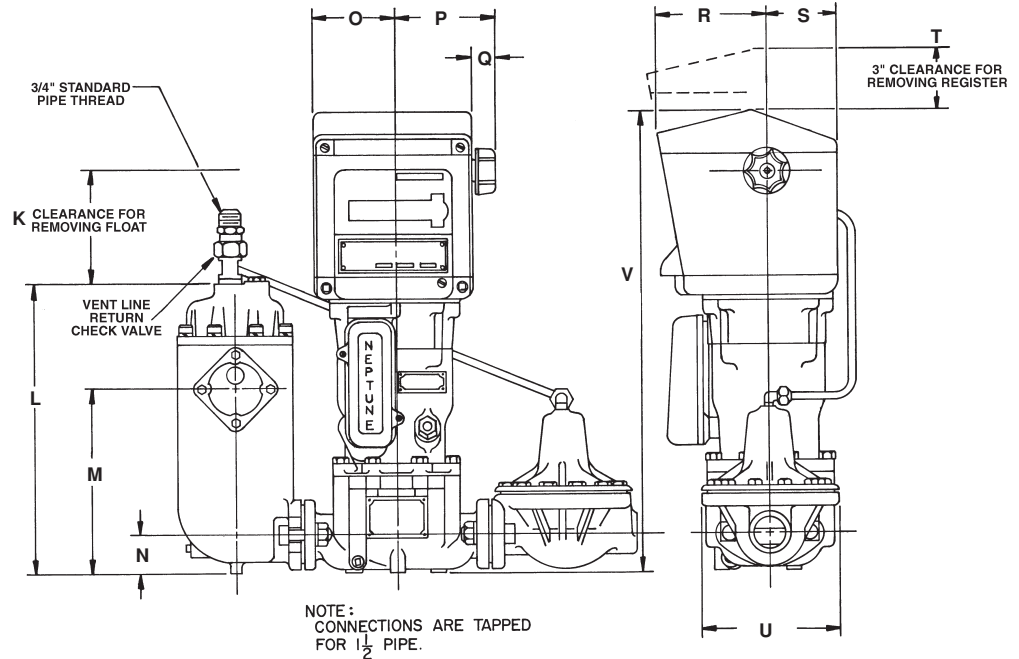
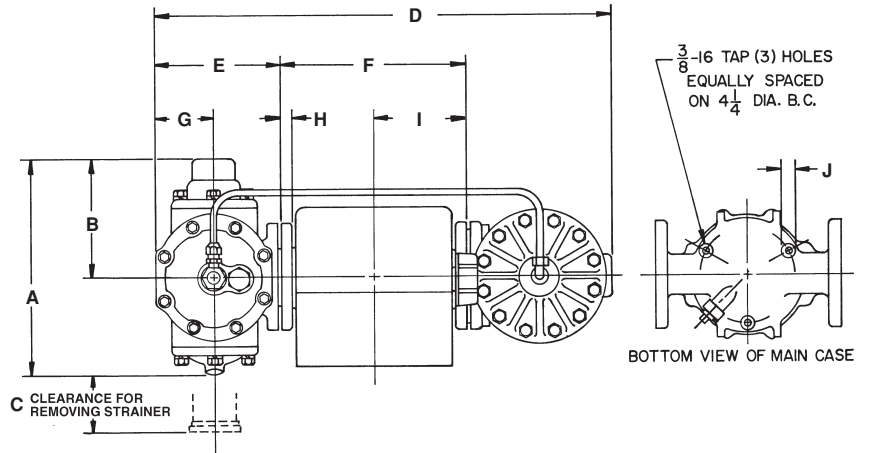

| DIMENSION V          | <i>in.</i> | <i>mm.</i> |
|----------------------|------------|------------|
| 1-1/4" uncompensated | 15.13      | 384.18     |
| 1-1/4" compensated   | 22.44      | 569.91     |
| 1-1/2" uncompensated | 15.81      | 401.64     |
| 1-1/2" compensated   | 23.13      | 587.38     |

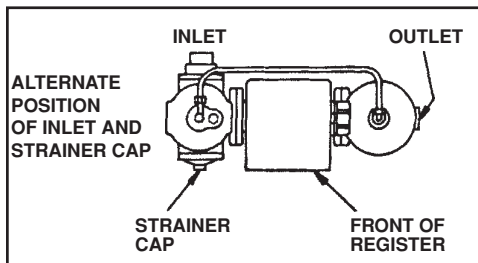

**ASSEMBLY OPTIONS**

Normal assembly is right hand flow: Inlet at left rear, flow to right outlet at Differential Control Valve.

right hand assembly

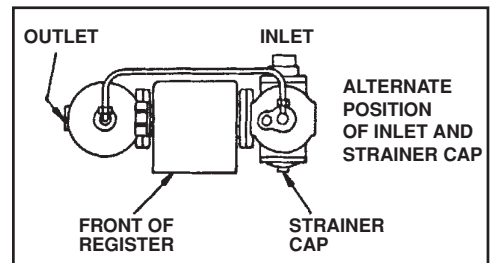

left hand assembly

**Accu-Flow**  
**Meter Service Ltd.**

4028 - 7th Street S.E., Calgary Alberta T2G 2Y8  
Phone: (403) 243-1425 Fax: (403) 243-6577  
Toll Free: 1-800-921-ACCU(2228), sales@accuflo.com



**U.S.A./International**  
1310 Emerald Road  
Greenwood, SC 29646-9558  
Tel.: Toll-Free (800) 833-3357  
(864) 223-1212  
Fax: (864) 223-0341



**RED SEAL**  
**MEASUREMENT**